

**ELLIET®**

MANUAL

**SNOWBOB  
8014T**



This booklet contains information for proper use and maintenance of the machine. **Read it carefully and store it in a safe place.**



Please **retain your sales invoice** or receipt copy along with this booklet.



**Register** your purchase online at **[www.eli.eu](http://www.eli.eu)** (active from September 2008. Before you need to return the filled-in garanty form to Eliet Europe NV).



Since Eliet is a Belgian company, all **measurements are shown in mm, kg and liter**. In Appendix G (p.91) you can find a conversion table with all the necessary data.

© ELIET

Copyright 2007 ELIET. All Rights Reserved. The texts, images, graphics... in this ELIET booklet are all subject to Copyright and other intellectual property protection. These objects may not be copied for commercial use or distribution, nor may these objects be modified or reposted for other use. Some parts this ELIET manual also contain material that is subject to the copyright rights of their providers.

# 1. Introduction

---



## 1.1 Please read the manual

---

Eliet machines are designed for safe and reliable use if they are operated in accordance with the instructions given. Carefully read these operating instructions before using the machine. Failure to observe this may result in personal injury or damage to the equipment.

## 1.2 Identification data - ELIET SNOWBOB 8014T

---

Note the identification data relating to your machine in the boxed areas.

Stock no.:	MA
Serial Number :	
Year of Manufacture:	20

# 2. Warranty

---



## 2.1 Warranty card

---

To be eligible to obtain warranty you must mail the completed warranty card within one month of the date of purchase to the address stated below. You can also register your product online at [www.eliet.eu](http://www.eliet.eu).

### European customers

ELIET EUROPE NV  
 Diesveldstraat 2  
 B - 8553 Otegem (Belgium)  
**T** +32 56 77 70 88 - **F** +32 56 77 52 13  
[www.eliet.eu](http://www.eliet.eu)

### US customers:

ELIET USA Inc.  
 3361 Stafford street (office B)  
 15204 Pittsburgh (PA)  
**Phone** 412 367 5185 - **Fax** 412 774 1970  
[www.elietmachines.com](http://www.elietmachines.com)

Read the warranty conditions on the attached warranty card.

### 3. Welcome

---



#### Welcome to the family of ELIET customers.

We would like to thank you for the confidence that you have placed in ELIET and we are convinced that you have purchased the very best machine. The operating life of your ELIET machine depends to a great extent on how you care for your machine. This operating manual and the motor manual provided will assist you in this respect. If you follow the instructions and suggestions in these manuals, your ELIET machine will operate for a very long time in optimal condition.

Read this instruction manual carefully before operating this machine. This will prevent you from operating the device incorrectly.

For your own safety, take into account the safety instructions specified in the relevant chapter. Even if you are thoroughly familiar with operating such equipment, it is still advisable to read these pages carefully.

At ELIET all our machines and devices are subjected to a policy of continuous change and therefore, the specification of your machine may differ slightly in terms of shape, technology and accessories. The descriptions and technical data in this manual are accurate at the time of printing. Certain illustrations and descriptions may not be applicable to your specific machine, but instead relate to a different version of the machine. In turn, we trust that you will understand that the texts and illustrations in this manual cannot lead to any claims.

If you still have any questions after you have read this manual, please contact your ELIET dealer.

#### ELIET AT YOUR SERVICE

##### European customers

GMT +1: from 8-12 AM, 13-18 PM

Diesveldstraat 2      **T** +32 56 77 70 88  
 B-8553 Otegem      **F** +32 56 77 52 13  
 Belgium              **E** Service@eliet.eu

##### US customers:

GMT +6: from 08:00 to 18:00

**Phone** 412 367 5185  
**Fax** 412 774 1970  
**Email** Service@elietmachines.com

## 4. Table of Contents

---

1. Introduction.....	3
1.1 Please read the manual .....	3
1.2 Identification data - ELIET SNOWBOB 8014T .....	3
2. Warranty.....	3
2.1 Warranty card.....	3
3. Welcome .....	4
4. Table of Contents.....	5
5. Safety symbols .....	7
5.1 For your information.....	7
5.2 Caution .....	7
5.3 Warning .....	7
6. Main parts.....	8
6.1 Overall view .....	8
6.2 Handlebars.....	9
6.3 Snow cutter head.....	10
6.4 225° variable blow chute .....	11
6.5 Engine.....	11
6.6 Hydrostatic pump and engine/differential/hydraulic disc brakes .....	12
7. Safety instructions .....	13
7.1 Safety messages .....	13
7.2 Safety features.....	14
7.3 Safety instructions .....	15
7.3.1 General safety instructions.....	15
7.3.2 Careful and proper use .....	16
7.3.3 Responsibility .....	17
7.3.4 Personal Protective Equipment (PPE) .....	18
7.3.5 Danger zone .....	19
7.3.6 Periodic maintenance .....	20
7.3.7 In harmony with nature .....	20
8. Dealer's duties.....	21
9. Operating instructions.....	22
9.1 Preliminary checks.....	22
9.2 Work site.....	23
9.3 Preparing the machine .....	23
9.3.1 Refuelling.....	23
9.3.2 Replenishing hydrostatic oil.....	24
9.4 Starting the petrol engine .....	25
9.5 Turning the engine off .....	26
9.6 Working with the machine.....	27
9.6.1 Prior to starting work.....	27

9.6.2 Moving the machine .....	27
9.6.3 Operating snow cutter head.....	31
9.6.4 Operating the blow chute .....	33
9.7 Fault diagnosis .....	34
9.7.1 The engine fails to start after idle periods.....	34
9.7.2 Engine switches off during operation .....	35
9.7.3 Engine loses power .....	36
9.7.4 Blow chute is stuck (no longer rotates) .....	38
9.7.5 Turbine/cutter is stuck or loses power.....	39
9.7.6 Moving a machine with a defective engine.....	40
10. Transporting the machine .....	41
11. Maintenance.....	43
11.1 General .....	43
11.2 Maintenance schedules .....	44
11.2.1 Periodic maintenance schedule.....	44
11.2.2 Opening the Snowbob's upper casing.....	45
11.2.3 Dismantling safeguards on the side of the machine .....	46
11.3 Cleaning the machine .....	46
11.3.1 The importance of cleaning .....	46
11.3.2 What does cleaning entail?.....	47
11.3.3 Cleaning ventilation grilles .....	48
11.4 Maintenance procedures.....	49
11.4.1 Engine maintenance .....	49
11.4.2 Maintenance on the hydrostatic pump .....	52
11.4.3 Machine maintenance.....	53
12. Winterizing the machine.....	70
13. Technical data.....	71
14. EC-Declaration Of Conformity - SNOWBOB.....	72
15. Appendices .....	73
15.1 Hazard analysis: .....	73
15.2 Meter display and functions.....	74
15.3 Warranty .....	76

## 5. Safety symbols



Certain symbols in this manual are used to provide additional information and to draw your attention to potential risks.

### 5.1 For your information



**For your information:**

This symbol is used to draw your attention to specific information and/or actions, or to denote where you can find additional information relating to the subject.

### 5.2 Caution



**Caution:**

This notice identifies safe usage habits. This is done to prevent incorrect actions that can result in personal injury or damage to the machine.

### 5.3 Warning



**Warning :**

This notice is used to warn you about extreme danger that you must be aware of in these specific circumstances. Thus remain alert, in order to ensure your own safety.

## 6. Main parts

To fully understand the content of this operating manual you need to be fully conversant with the terminology used for the descriptions. This chapter refers to a broad range of machine parts and identifies their names. We recommend that you take the time to study the machine prior to its use for a better understanding of the descriptions provided in this operating manual.

### 6.1 Overall view

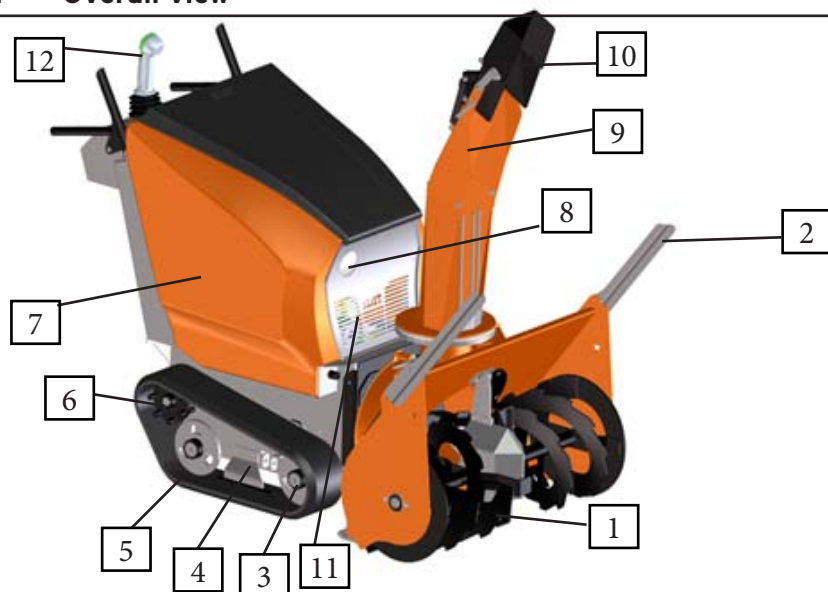

- |    |                         |     |                         |
|----|-------------------------|-----|-------------------------|
| 1. | Snow cutter head        | 7.  | Engine protection guard |
| 2. | Drift cutters           | 8.  | Light                   |
| 3. | Tensioning wheel        | 9.  | Blow chute              |
| 4. | Caterpillar track guide | 10. | Directional valves      |
| 5. | Caterpillar tracks      | 11. | Suction grille cool air |
| 6. | Driving sprocket wheel  | 12. | Operating console       |



## 6.2 Handlebars



### For your information:

All references to front, rear/back, left and right in this manual are from the viewpoint of the operator using the Snowbob and standing with his hands on the handlebar.



1. Dead man's lever
2. Light switch machine
3. All-in-one Joystick
4. Release handle snow cutter
5. Start/stop key
6. Thrust lever
7. Choke
8. Maintenance meter
9. Cutter head operating switch
10. Hot air grilles

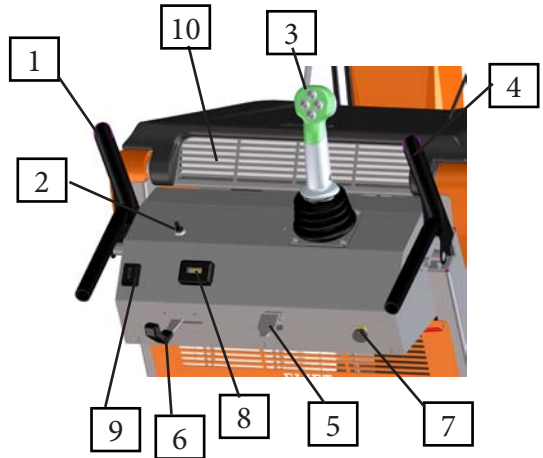

## 6.3 Snow cutter head

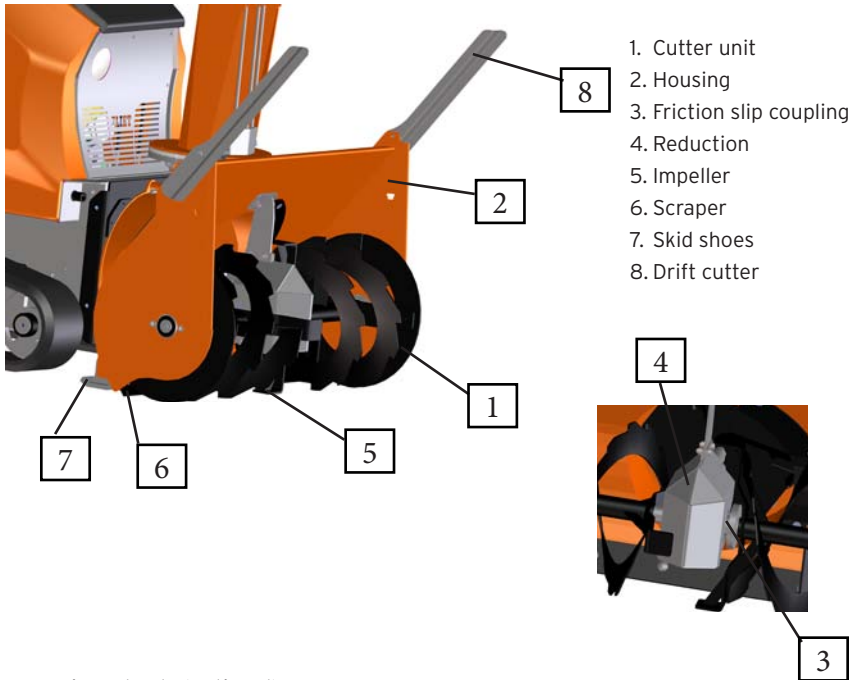

### Running wheels (optional)

Whenever constant use of the Snowbob is required on hardened surfaces (e.g., concrete, asphalt), as is customary for clearing parking lots, driveways, terraces, etc. ... the skid shoes will quickly wear down. These skid shoes can be replaced by support wheels as an optional alternative. These wheels are made of heavy rubber with a special track-pattern, whereby damage to the pavement will be avoided.



(Standard skid shoes)



(optional: running wheels)

## 6.4 225° variable blow chute

1. Turbine
2. Directional guide valves
3. Actuator for directional guide valves (electric)
4. Engine blow chute orientation (electric)
5. Actuator lifting cutter head (electric)
- 6.

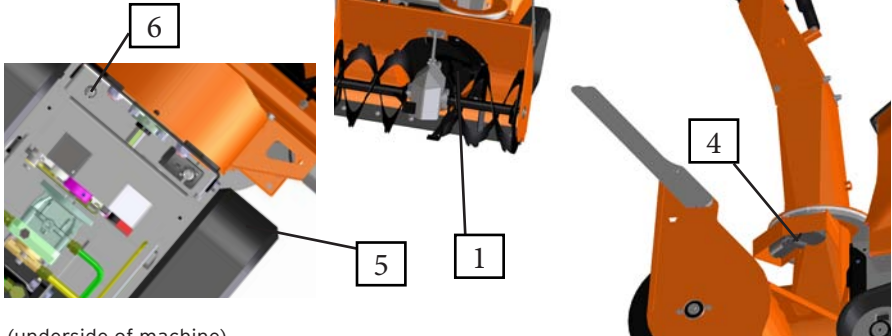

(underside of machine)

## 6.5 Engine

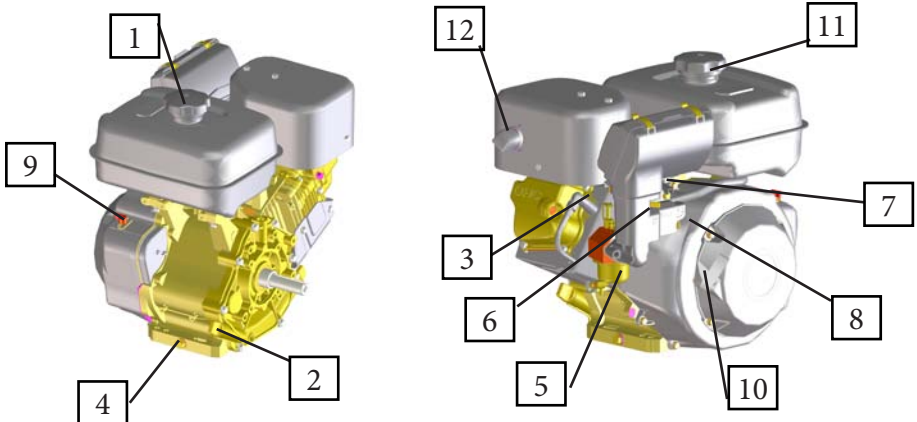

1. Air filter box (air filter not present for this application)
2. Oil dipstick and oil filler cap
3. Spark plug (2)
4. Oil drainage
5. Choke
6. Fuel tap

7. Speed control
8. Damper
9. Engine ignition lock
10. Starter handle
11. Fuel filler cap
12. Exhaust

## 6.6 Hydrostatic pump and engine/differential/hydraulic disc brakes

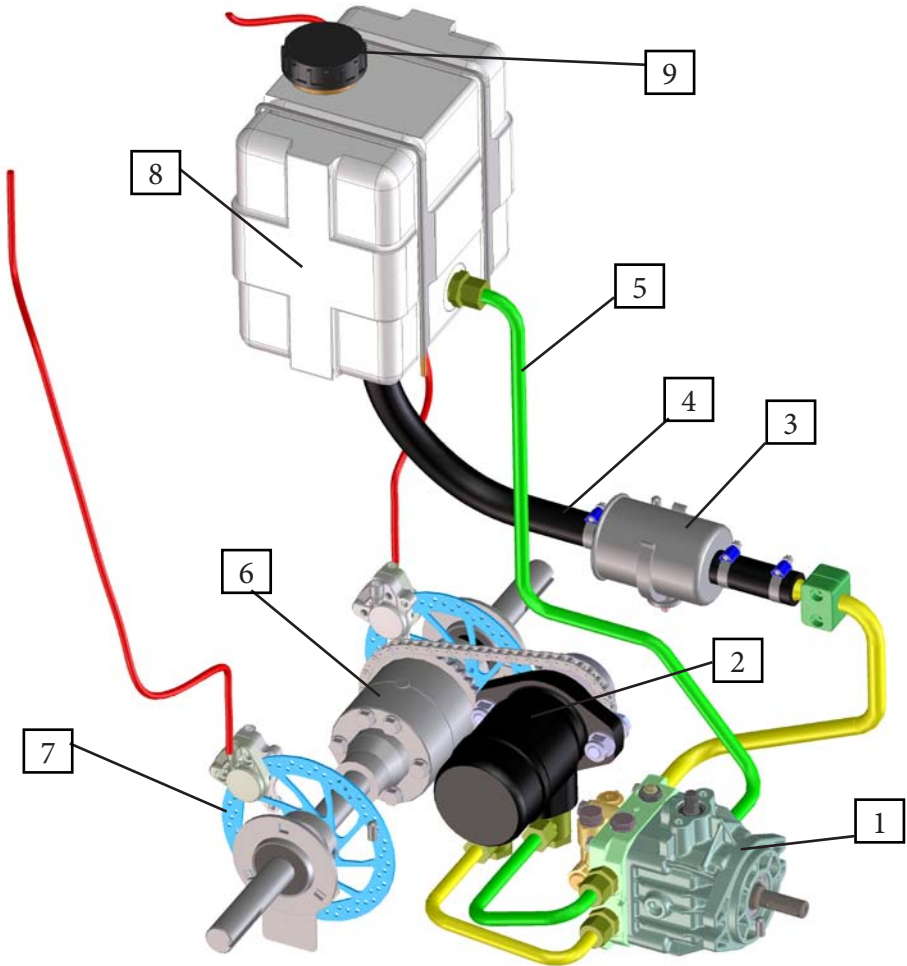

- |    |                    |    |                           |
|----|--------------------|----|---------------------------|
| 1. | Hydrostatic pump   | 6. | Differential              |
| 2. | Hydrostatic engine | 7. | Hydraulic disc brakes (2) |
| 3. | Filter             | 8. | Hydrostat tank            |
| 4. | Suction pipe       | 9. | Filler cap                |
| 5. | Return pipe        |    |                           |

## 7. Safety instructions

### 7.1 Safety messages

Safety messages are provided via stickers that are applied to the machine. Take good notice of the symbols and warning messages displayed.

Some safety instructions are symbolised by icons:



1. Before operating the machine the manual should be read and understood.



2. Suitable safety clothing (gloves, safety goggles, ear defenders) should be worn when operating the machine.



3. Keep third parties at a safe distance from the machine when it is in operation (5m).

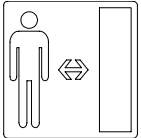

4. There is a real risk of severe injuries including permanent damage to the hands and feet. Keep hands and feet a safe distance from the snow cutter at all times.

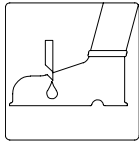
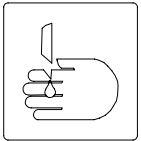

5. There is a real risk of severe injuries with permanent damage to the eyes or face as a result of flying debris. Always keep a safe distance from the machine when it is being used.

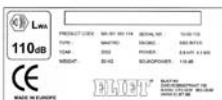
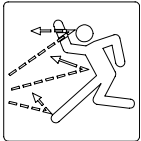

This sticker is the identity label for the machine and contains the following data:

- Year of manufacture
- Model
- Type number
- Serial number
- Capacity
- Weight
- Guaranteed A-weighted noise level

In addition, the sticker bears the information about the manufacturer. The sticker bears the seal of conformity with European standards in the form of a CE label. In accordance with European directive 2000/12 EC, this sticker indicates the guaranteed noise output (LWA) of the machine in dB(A). This important sticker must be replaced in the event of becoming damaged or illegible.



**Caution:**

Safety stickers becoming damaged, illegible or removed through use or cleaning, must be immediately renewed. Stickers are available at your approved ELIET Dealer.

## 7.2 Safety features



**Lighting:**

The Snowbob 8014T is equipped with lighting so that you always have a good view of your work zone.



**Dead man's handle:**

This handle is located on the handlebars. This is a general release level that takes priority over the others. Once this handle is released, the cutter will come to a halt as will the drive to the caterpillar tracks.



#### **Friction slip coupling:**

This slip coupling ensures that the cutter disengages when it comes into contact with a foreign object. This protects the cutter from breaking or projecting objects that could wound bystanders.



#### **Snow tracks:**

ELIET has selected top quality Bridgestone tyres for the caterpillar tracks on the Snowbob. These caterpillar tracks, which have been especially developed for working in snow, provide optimum grip on the ground.

## **7.3 Safety instructions**

---

### **7.3.1 General safety instructions**

- The owner of the machine will keep this manual during its complete service life. A reference guide for the user, it also ensures that the machine is used and maintained correctly at all times. Always refer to this instruction manual if you have any doubts about operations that you are about to perform.
- If the instructions stated in this manual are not clear to you, do not hesitate to contact your ELIET dealer for further explanation. The help desk at ELIET NV/SA is at your service to answer all of your questions. (EU +32 56 77 70 88 - USA 412 367 5185). (service@eliet.eu)
- Be sure to read the chapter which is intended for the dealer (see chapter 8 Dealer's duties) and verify whether the machine was delivered in accordance with the instructions.
- After you purchase the machine, allow the dealer or a professional to give you some instructions regarding correct use.
- Carefully observe all safety instructions when using this ELIET machine! Carefully read all the instructions relating to the operation of the machine. They are important for your own personal safety.
- Always observe the applicable regulations of the Labour Inspectorate to avoid accidents.
- Under no conditions whatsoever may the original design of the machine be modified without explicit and written consent of ELIET EUROPE NV.



### **For your information:**

Also read the safety instructions in the engine manual. It contains useful tips about proper use and maintenance of the engine.

- Read and observe all safety messages labelled on the machine. (read § 7.1 Safety Messages in order to locate stickers)

## **7.3.2 Careful and proper use**

- Avoid inhaling the machine's exhaust fumes. Exhaust fumes contain toxins, which can lead to poisoning and result in death. Consequently, the engine may never run in a closed environment for more than 30 seconds.
- This machine is designed to move snow from one area to a more suitable location and must be used for this purpose only.
- Clearing snow is a physically demanding task and it is therefore advisable to take sufficient breaks and consume adequate food and drink.
- It is unsafe for persons with heart problems and/or balance disturbances to operate the machine.
- Think about what you are doing at every manoeuvre. Do not be tempted to let routine dull your attention. Never act impulsively or on reflex.
- Despite the extensive safety features, do not seek out dangerous situations (read appendix 7, which contains an indicative list of dangers).
- Never work with a machine that has not been fully assembled. Check the finish of the machine to ensure compliance with the instructions provided in this manual.
- The snow cutter can cause severe injuries. Always keep hands and feet away from the cutter when the engine is running. If you must work in the vicinity of the Snowbob, switch off the engine.
- If the blow chute becomes blocked, switch off the engine before commencing maintenance work. Never put your hands in the blow chute if the engine is running. Use a wooden stick to remove the obstruction.
- The snow clearer may propel sticks and stones; this could lead to severe injury. Always check the working area for loose stones, sticks, nails, bits of wire, and so on.
- Never work when light intensity is below 500 Lux.
- Never attempt to change a machine setting and never perform maintenance when the engine is running.
- The machine may cause an explosion if you work near flammable products, fumes, etc..



## BATTERY

- When working on the battery, insulated tools and protective clothing, such as goggles, gloves and apron, must be used at all times. The electrolytic fluid is dilute sulphuric acid; this is an extremely corrosive substance.
- In the event of contact with the eyes/skin, immediately clean with plenty of clean water and, if necessary, consult a doctor.
- Metal objects or other conductors can lead to short circuiting if they come into contact with the poles of one or more cells.
  - If they heat up, the short circuited cell(s) could cause burns.
  - Never place tools or other conductive material on the cells.
  - The battery must be charged in a suitable area.
  - First aid (eye bath) and fire-fighting equipment must always be near to hand.
- Smoking, naked flames, welding and grinding are all forbidden in the vicinity of the battery.
- All battery maintenance should be carried out by an expert and suitably qualified personnel!
- When installing a new battery, always connect the (+) first and then the (-).
- Disconnecting the battery must be done in reverse order, i.e. first the (-) and then the (+).
- Always use a battery with the same characteristics as set out in this manual. If this is not respected, it may lead to a fire hazards.
- If wiring needs to be replaced or repaired, only use suitable wiring. Respect the specifications of the original wiring (wire selection, insulation,...).

### 7.3.3 Responsibility

- The operator of this machine is assumed mature enough and with enough common sense to make decisions by himself.
- All persons using the machine are assumed to be fully conversant with the safety instructions. The operator is fully liable for the use of the machine in regard to himself and to third parties.
- The machine may not be operated by underage persons. This does not apply to youths over 16 who are learning to operate the machine under the supervision of an experienced operator.
- Children and animals must be kept outside the machine's danger zone. A minimum distance of 10 meters must be observed.
- ELIET advises against lending the machine to others. However, if this should occur, it should only be lent to persons who are familiar it. Always make sure that the user is aware of the potential hazards and ensure that he/she reads the manual before using the machine. (Appendix B1 contains a list of indicative dangers)
- This machine must only be operated by persons who are well-rested and in a good physical condition. Take a rest if you become tired whilst operating the machine.
- Do not operate the machine after alcohol or hallucinogenic drug use.

- The user is also advised to be thoroughly familiar with the site itself. This enables the user to gain a greater insight into possible obstacles that may present themselves and he can then plan his route around them.
- The user must draw up a list that registers the number of hours worked. This will ensure that the repetitive maintenance schedule can be followed correctly in relation to the machine.



**Warning:**

A moment of distraction or carelessness can lead to life long regret.

### **7.3.4 Personal Protective Equipment (PPE)**

- Suitable clothing must be worn when operating this machine. This means clothing that covers the entire body. Sturdy gloves and enclosed shoes with steel toecaps and gripping soles are useful for this type of work.
- Clothing must never be worn loosely.



**Caution:**

If wearing a scarf, do not forget to tuck the ends in your jacket or your jumper.

- If the user has long hair, it should be secured in a pony tail and kept in place with a cap, hat or headband.
- For protection of the most sensitive senses, ELIET recommends hearing protection and protective goggles.
- Pay particular attention and be careful when using hearing protection as they can impair the ability to hear warning sounds (such as yelling, signal tones, etc.). ELIET thus advises against using hearing protection with built-in music devices or the use of a "Walkman" or portable MP3- player while working.
- As indicated on the safety sticker on the machine, the operator must wear safety gloves and safety goggles in addition to hearing protection.
- The use of mittens is not advised as they impede the ability to operate the machine. You are advised to wear gloves with individual fingers.



#### For your information:

The operator of the machine can reduce the risk of injury by wearing the proper personal protection equipment.

### 7.3.5 Danger zone

The image below shows the position of the operator and the machine's danger zone:

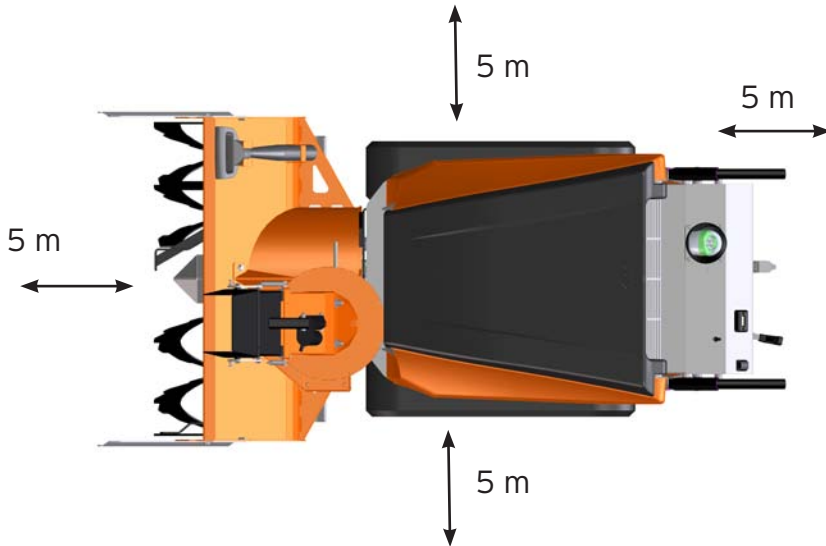

- Never allow bystanders within the danger zone stretching up to 5 m around the machine during work.
- Do not take any risks and immediately stop the machine as soon as anyone enters the danger zone. (read § 9.5 Switching off the engine)
- Children and animals must be kept well away from the machine.
- Shut off the engine when leaving the machine unattended.
- Once the engine is running, focus all your attention on operating the machine.
- Protective covers are intended to shield off dangerous areas to avoid accidents. It is therefore strictly prohibited to operate the machine or to activate the engine or any drive with any protective cover removed.

### **7.3.6 Periodic maintenance**

- Periodic maintenance is essential. You must therefore strictly follow the maintenance schedule in this operating manual (see § 11.2.2).
- Draw up a maintenance register in which you keep the performed maintenance updated in detail.
- If parts must be replaced as a result of wear or failure, you must always turn to your authorised ELIET dealer for original replacement parts. This is of key importance for your own safety. (Find an authorised ELIET dealer near you on [www.eliyet.eu](http://www.eliyet.eu)).
- For a list of original spare parts and their ordering codes please visit [www.eliyet.eu](http://www.eliyet.eu).
- Repairs, maintenance and cleaning work may only be conducted when the engine is not running, the starter key is in the OFF position and has been removed from the ignition.
- Always wear suitable clothing for performing maintenance.

### **7.3.7 In harmony with nature**

Use the machine in a manner that respects environmental regulations:

- a) Avoid running the machine without actively using it.
- b) Avoid spilling petrol while refuelling.
- c) Oil leaks in the engine or transmission should be repaired immediately.
- d) Service the engine regularly for optimum combustion.
- e) Any waste materials resulting from performing maintenance on the machine should always be disposed of properly and in their designated place either for recycling or other environment-friendly processing.

## 8. Dealer's duties

---

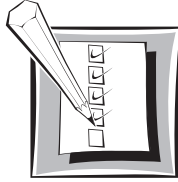
**Caution:**

As an ELIET Dealer you should familiarize your customers with the functioning of the machine and also point out the possible dangers while using it. You are expected to carefully go over the maintenance points of the machine together with the new owner. Repeat these instructions until the new owner has fully understood everything.

- ELIET machines are packaged in accordance with common rules for proper transportation. Deliveries are always ex factory. Consequently, ELIET cannot be held liable for any damage that occurs during transport.
- If the packaging is damaged upon receipt of the goods, check the state of the machine to ensure it is not damaged. Report any irregularities on the delivery order before signing for receipt.
- In case of damage to the machine a complaint to the shipping company must be submitted immediately after delivery.

Finally, make sure that the warranty card is filled in completely and signed. This is to avoid any warranty disputes. Please read the warranty conditions for more details.

Please register your product online immediately after purchase to ensure that your warranty entitlement is activated. ([www.elieta.eu](http://www.elieta.eu)).

## 9. Operating instructions

### 9.1 Preliminary checks



**Caution:**

Before starting the work, you are advised to get into the habit of checking the following points:

Checklist

- A. Perform a visual inspection of the condition of the machine.
- B. Check that the fuel tank is full. If not, fill it up (Read § 9.3.1 Refuelling)
- C. Check whether the hydrostatic oil tank is full. If not, replenish the oil (Read, if necessary § 9.3.2 Replenishing hydrostatic oil).
- D. Check the oil level in the engine. Pull out the dipstick and check whether the oil level is below the minimum.
- E. Check that all safety provisions on the machine are still operating properly. (See § 7.2 Safety Features).
- F. Check whether the joystick is in the 0 position and make sure it has not been left in cruise-control.
- G. Check whether the skid shoes on the cutter head are still set correctly. To do so, you are referred to § 11.4.3.6 Setting Cutter Blade
- H. Check whether the cutter head is raised for transport.
- I. Check the work site for any objects that could be catapulted into the air. (Read § 9.2 Work site).
- J. Check that all lights on the Snowbob are working. If a bulb is broken, replace before starting work.
- K. Check that all safety stickers on the machine are still visible. If this is not the case, replace them.
- L. Check that the rotary movement of the blow chute is still working. (Read § 9.7.4)
- M. Check that all of the contacts or connection points for electric cabling are still watertight. Check the shrink sleeves and all silicon seals (particular in relation to the cabling to the cutter head and the blow chute). Repair if necessary.

## 9.2 Work site

---

So as to avoid damaging the machine and to guarantee a good quality of work, a number of conditions are set in relation to the site:

- Remove visible foreign objects (twigs, pipes, loose stones, ropes, sticks...) from the site before starting work. This helps prevent objects being catapulted outwards and causing potential injuries to bystanders.
- You are also advised to mark obstacles that have been encountered previously with a stick or another marker.

## 9.3 Preparing the machine

---

### 9.3.1 Refuelling

When petrol in the machine is running low, it must be refuelled. The use of fresh petrol is recommended at all times. Use unleaded petrol, preferably with an octane index of 98 or 99.



#### **Warning:**

Under certain conditions, petrol is extremely flammable and highly explosive. Fires and petrol explosions can inflict severe burns and cause damage to personal property. Consequently, the following points should be observed:

- Never add petrol whilst the engine is running. Always allow the engine to cool off for several minutes prior to fuelling.
- Only use fresh petrol. ELIET is environmentally conscious and, therefore, recommends using unleaded petrol with an octane of 98 or 99. To preserve fuel freshness for longer periods of time, additives may be used.
- Store the petrol in an approved tank. Keep out of reach of children.
- Never refuel at the location where the machine is later to be operated. Keep a distance of at least 10 m from the selected work area. Doing so will avoid creating a fire hazard.
- The fuel tank is on the left hand side of the machine and has a total capacity of about 18l.
- Clean off the area around the cap of the fuel tank and remove it.
- Take note that a fuel filter can be inserted into the opening of the tank. Refrain from pouring too quickly; allow the petrol sufficient time to penetrate the filter without overflowing.
- If there is no tank sieve present, then select a funnel with a filter that can be used to keep unwanted rubbish from getting into the tank.

- Do not fill the tank completely. Fill up to approximately 10 millimetres from the brim. So never fill it up to the brim.
- Put the cap back on the fuel tank as quickly as possible. Immediately clean up the tank/machine if any petrol is spilled whilst refuelling.
- Also be aware that clothing does not come in contact with the petrol. If this happens, the clothing should be immediately changed.
- It is irresponsible and, thus, strictly forbidden to refill the tank in the vicinity of smokers or near an open fire.
- If fuel is swallowed or comes in contact with the eyes, consult a doctor immediately.

### **9.3.2 Replenishing hydrostatic oil**

Only use suitable hydraulic oil with a viscosity of 46cSt (according to DIN 51524-3 HVL.PVB) for replenishing the hydrostatic reservoir. Eliet advises using SUNOCO Sunvis 846 WR HV.

- Never replenish oil if the engine is running. Always allow the engine to cool off for several minutes prior to replenishing oil.
- Store the oil in an approved tank. Keep out of reach of children.
- Never replenish oil at the location where the machine will be operated. Keep a distance of at least 10 m from the selected work area. Doing so will avoid creating a fire hazard.
- The oil tank is on the right hand side of the machine and has a total capacity of about 5l.
- Clean off the area around the cap of the oil tank and remove it.
- Use a funnel with a filter to keep unwanted rubbish from getting into the tank.
- Do not fill the tank completely. Fill up to approximately 10 millimetres from the brim. So never fill it up to the brim.
- Put the cap back on the tank as quickly as possible. Immediately clean up the tank/machine if any oil is spilled whilst replenishing.
- Also ensure that clothing does not come in contact with the oil. If this happens, the clothing should be immediately changed.
- It is irresponsible and, thus, strictly forbidden to refill the tank in the vicinity of smokers or near an open fire.
- If oil is swallowed or comes in contact with the eyes, consult a doctor immediately.



#### **Warning:**

Oil shortage in the hydrostatic pump inevitably causes severe damage. (This type of defect is not covered under warranty).



## 9.4 Starting the petrol engine

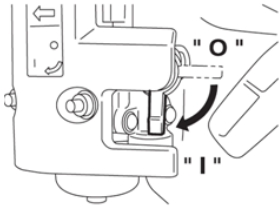

- Open the fuel tap by turning the lever to the "I" position

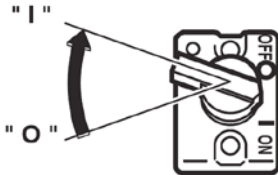

- Set the engine's ON/OFF switch to ON

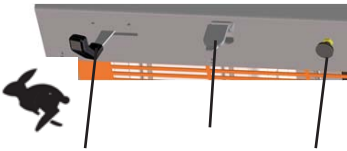

- Set the gas lever to full.
- Pull the choke out and turn the starter key to START position.
- Press the choke half in. Depending on the weather conditions, you can then push the choke back fully.

**Note:** You can also start the petrol engine using the starter handle on the left hand side of the machine.





### Warnings:

- Under no circumstances should you ever allow the engine to run for an extended period (i.e. more 30 seconds) in a closed space. The exhaust fumes contain toxins that may cause poisoning or suffocation.
- Before starting the engine, check that ventilation grilles are not blocked by any foreign objects.
- If the engine does not start immediately, wait for a short while (> 5sec) before trying again. If you do not do so, you may well damage the engine.
- Repeated, unsuccessful attempts to start the engine may point to a wet spark plug. It must then be cleaned or replaced. Other possible causes can be found in "§ 9.7.1 The engine will not start after a period of inactivity."
- Make sure the cutter head is raised for transport. You set speed via the large joystick in the centre of the dashboard. If the joystick is moved forward, the Snowbob will move faster. The Snowbob will go backwards if you pull the joystick towards you.
- The direction in which you wish to move is set using the large joystick in the centre of the dashboard. If you wish to go left, move the joystick towards the left. If you wish to go right, move the joystick towards the right.

## 9.5 Turning the engine off

- You are advised to put the central joystick in a central position (0 position) before switching off the engine; in other words, do not leave it in the cruise-control position. You thus prevent the machine from starting to move as a result of using the dead man's handle when starting the machine.
- Release all levers.
- Set the thrust lever to slow speed.
- Turn the starter key to the OFF position, remove the key from the lock and close the ignition using the cap.
- Keep the key in a safe place but outside the reach of children and any unauthorised persons.



### For your information:

The machine is hard to move when the engine is switched off. It is therefore advisable to first move the machine to the desired location before switching the engine off.

## 9.6 Working with the machine

### 9.6.1 Prior to starting work



#### Warning:

Never run the engine in a closed environment for over 30 seconds. There is a risk of carbon monoxide poisoning from the exhaust if you do so. If the machine is stored inside, doors and windows will be opened for maximum ventilation before starting the engine to move the machine.



#### Caution:

Sturdy shoes that provide sufficient support and adequate protection must be worn when working with the machine. There is a risk of the machine passing over the feet during an erroneous manoeuvre. Ensure that the soles of the shoes have sufficient grip so that you do not slip on icy or frozen ground.

#### Important:

Before starting work, ensure that the cutter head's skid shoes are correctly aligned. To do so, you are referred to § 11.4.3.6 Setting Cutter Blade

### 9.6.2 Moving the machine

The Snowbob 8014 T is equipped with 2 caterpillar tracks. These two, wide rubber tracks are driven by a differential. The differential is, in turn, driven by a hydraulic engine via a chain transmission. The hydraulic engine is linked to a hydrostatic pump.

The facility to regulate the flow of each pump separately means that the speed of the engine and the track can be set. This regulation is proportional so that speed is infinitely adjustable. Each of the track's drive shafts is fitted with a hydraulic disc brake. Moving the joystick to the left engages the left brake, allowing the other track to receive more power and, consequently, turning the machine to the left. The reverse is true if the lever is turned to the right.

In order to simplify operation, the drive for this regulator is centralised in the central, All-In-One (AIO) Joystick on the dashboard.

### How is the drive engaged?

The hydrostatic drive uses a belt transmission. The belt must be engaged in order to activate the hydrostat and provide power to the tracks. The belt drive can be engaged by pressing the dead man's handle.



#### Caution:

In order to avoid the machine moving unexpectedly when depressing the dead man's handle, check that the AIO control handle is in the neutral position and not in the cruise control position.

### Which transport characteristic will be selected?

The machine can be relocated in work mode or in transport mode.

A. In **transport** mode, the operator wishes to move the snow clearer across larger distances or between two work zones. The main aim here is to move quickly and not lose functional time. The snow cutter will, therefore, be disengaged and the cutter head will be raised so that it no longer touches the ground or snow. This provides all of the power to the drive generator and means that the cutter head will no longer impact upon the movement freedom of the machine.

B. In **work** mode, the aim is to clear snow. It is thus important to achieve optimum clearance performance; the task is thus to adjust drive speed to the machine's clearance capacity. This is variable and depends on the height of the mass of snow, the density and composition of the snow and the grip and evenness of the ground. Moving in work mode will therefore be slow and restrained.

### How is the machine steered?

The Joystick can be pushed in any direction. Each movement, however, is mechanically translated into a setting on the hydrostatic pump regulator (forwards/backwards) and power (or not) to the hydraulic brakes (left/right):

1. AIO Joystick is moved forward - the tracks move forward and the machine moves forward. The further the Joystick is moved forward, the quicker the machine moves.
2. AIO Joystick is moved backwards - the tracks move backwards and the machine reverses. The movement speed will depend on the extent to which the Joystick is moved backwards.
3. If the AIO Joystick is moved to the left, the right track will be driven faster and the left will be driven slower. This speed difference will result in the machine turning to the left. The more intense the Joystick movement to the left, the greater the speed difference on the two tracks and the further the machine will turn. A certain, sideways Joystick position will cause the left track to come to halt and leave only the right hand track moving; this will lead to the machine turning around the static track. If the Joystick is moved still further

sideways, the left hand track will begin to turn backwards and the machine will turn on its axis. This is called a “zero-turn” turning circle.

4. The same applies if the AIO Joystick is turned towards the right but then in reverse directions.

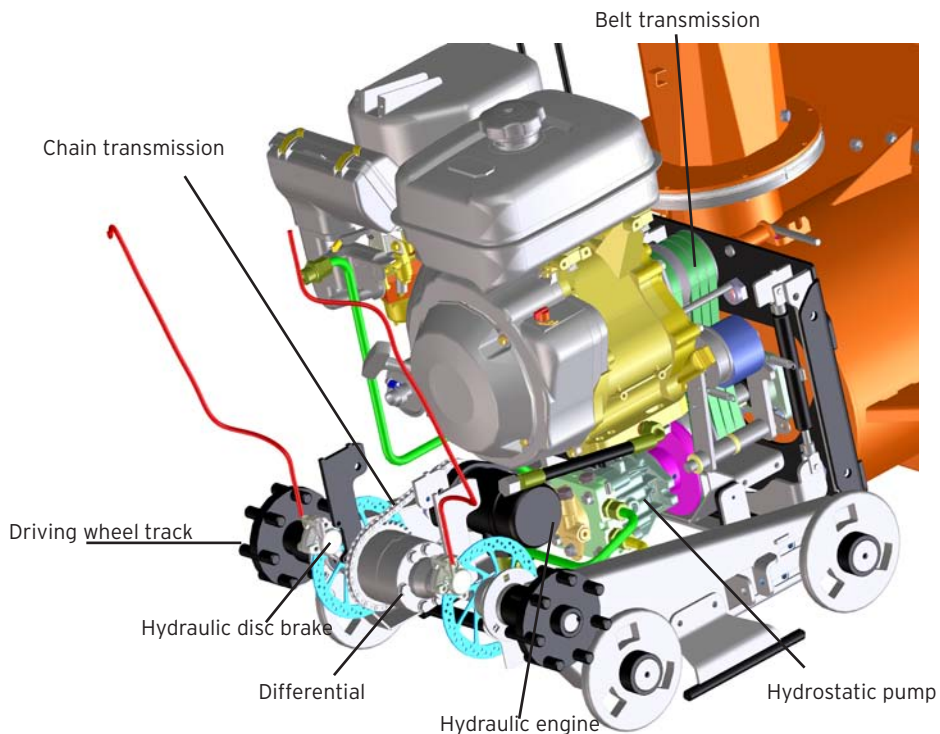

Operation is very intuitive as the Joystick only has to be turned in the direction that the operator wishes to steer the machine.

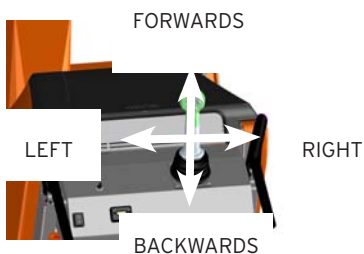

**Caution:**

If a situation occurs in which the operator seems to be losing control of the machine, the dead man's handle should immediately be released. The drive on the hydrostat will immediately halt and the machine will thus stop.

**For your information:**

- Depending on the selected speed, there is still proportional regulation within this setting using the Joystick. If, during certain conditions (loading/unloading or parking), this does not provide the required speed, however, the dynamic of the machine can be further influenced by reducing gas.
- If, in certain situations, 1 track begins to slip, this can be resolved by moving the joystick to the same side as the slipping track. As a result, the brake will be engaged, meaning that this track will not receive full power and that some will go to the other track (differential function).

**Cruise control**

The AIO control lever is designed so that it returns to the neutral position by itself when it is released; this then brings the machine to a halt.

If a set speed must be retained during movement, the AIO Joystick must therefore be constantly held in a particular position. This means that the arm and wrist must be held in the same position for long periods when working. This can lead to cramps or weariness. To avoid this, a cruise control has been provided on the machine. (Read § 11.4.3.8 Setting cruise-control). This function ensures that the Joystick movement becomes stiffer when going forwards or backwards and does not return to the neutral position of its own accord. As a result, the Joystick retains its position and allows the machine to continue at a fixed speed without being actively operated.

**Caution:**

The use of this cruise-control function means that the operator must move the AIO Joystick back to the neutral position if the dead man's handle is released in order to avoid the snow clearer immediately resuming this speed when started again.

### 9.6.3 Operating snow cutter head

The Snowbob's cutter head has an operational width of 80 cm and a clearance height of 56 cm. In cooperation with Parker, an electro-hydraulic suction device has been developed, allowing the cutter head to be tilted at angles from -30mm to +200 mm. Moving the cutter head from its nethermost to its uppermost position takes less than 5 seconds.

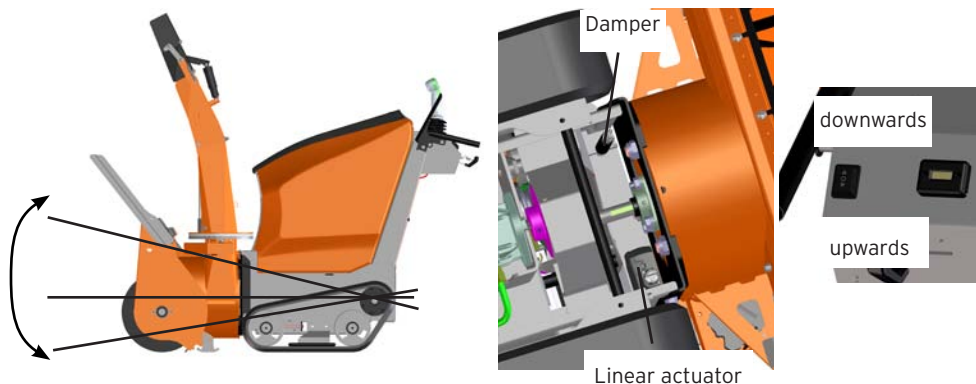

When, during the snow-clearing operation, one wants to go into reverse, it is recommended that the cutter head be lifted up.

#### Releasing the cutter head

There is also an option to release the cutter head. This is achieved using the lever (1) that is mounted on the cutter head in the vicinity of the electro-hydraulic suction device. The cutter head then rests on the skid shoes and follows the surface of the ground. This means that the operator no longer has to continuously adjust the cutter head with the joystick. This is very handy if snow has to be cleared on a car park where the surface is smooth or slightly sloping.

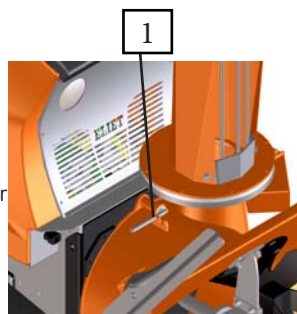

#### **Caution:**

- The movement of the cutter is limited if this function is used. Be aware of this!
- The cutter head may not be released at locations with an undulating surface. This would increase the risk of damaging the cutter if it were to encounter a foreign object.

### Starting the cutter

The moveable cutter head is powered by a joint transmission.

The cutter is started by pressing the black lever on the right hand side of the handlebar.

When operating the dead man's handle, the black lever will remain in position. As a result, the user is able to operate the machine using the central joystick on the console with his right hand. When the dead man's handle is released, the drive motion and the cutter stop.



#### **Caution:**

When working with the Snowbob, the operator should always stay in position while the cutter head is turning. Contact with the cutter head when moving could lead to severe injuries.



## 9.6.4 Operating the blow chute

### Variable blow chute

The position of the blow chute is electrically controlled and is located on the joystick for ready access. The left and right operational buttons on the joystick are used to select the direction of the blow chute.

Within a radius of 225°, the operator can easily fix the direction in which he wishes to throw the snow.

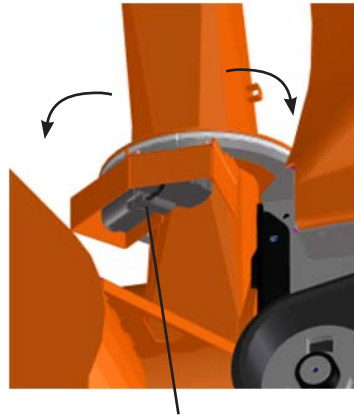
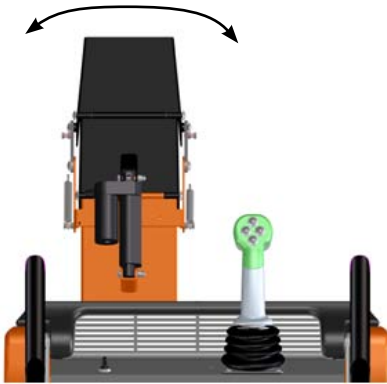

Electric engine

### Directional guide valves

The directional valves on the variable blow chute can be controlled electrically with the joystick.

Moreover, the actuator has been mounted by the directional valves, which eliminates the need for cables. The upper and lower operational buttons on the joystick are used to move the upper valve on the blow chute upwards and downwards, respectively.



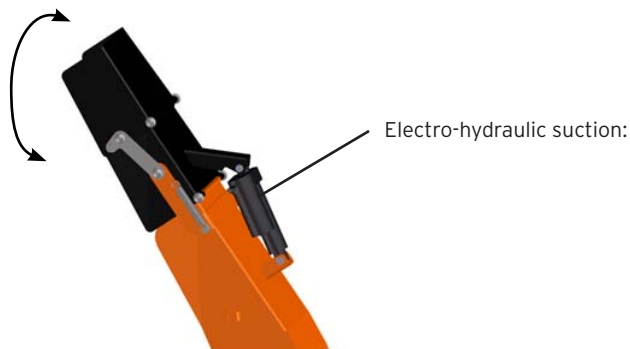

## 9.7 Fault diagnosis

### 9.7.1 The engine fails to start after idle periods.

If the machine fails to start up after periods of inactivity, then this could be the result of any of the following causes:

- a. Low on petrol
- b. Petrol is stale
- c. Bad sparkplug
- d. Low on oil



#### Caution:

Before examining possible reasons for the fault, the starter key must always be in the OFF position.

#### a. Low on petrol

In § 12 - Storing the machine - you are advised to remove any residual petrol before long term storage of the machine. You may, therefore, have forgotten to refill the machine.

Check that the tank is adequately filled and refuel if necessary (read § 9.3.1)

Let the starter engine run for a while after refuelling. Close the throttle (choke) - the petrol will now be sucked into the line. The engine will start running as soon as the carburettor has filled.

**b. Petrol is stale**

Petrol has a limited shelf life. Petrol that has been sitting in petrol tank for more than a few months can cause starter problems. It also smells totally different than fresh petrol. Pump out the contents of the fuel tank and refuel with fresh petrol. (Read §9.3.1) (CAUTION: even stale petrol can still be incredibly flammable.

**c. Bad sparkplug**

Without the proper ignition, it will be impossible to get the engine up and running. For this reason, check the sparkplug. (Read § 11.4.1.7 Switching off the engine)

**d. Low on oil**

The engine's crankcase is filled with engine oil to lubricate and cool the pistons. Lack of oil can lead to increased wear of the engine. To protect the engine, the machine has been equipped with a control switch that will disengage the engine if the machine is low on oil. Check the oil level and refill if necessary. (Read § 11.4.1.1.1 and § 11.4.1.1.2)

## **9.7.2 Engine switches off during operation**

If the engine suddenly shuts off during operation, this could be the result of a number of factors:

- a. Low on petrol
- b. Lack of oil in the engine
- c. Machine is on a slope
- d. Technical defect

**Caution:**

Before examining possible reasons for the fault, the starter key must always be in the OFF position.

Take the following steps to restart the machine in case of one of the following:

**a. Low on petrol**

If the operator is so absorbed in his work that he fails to notice that the indicator is showing that the petrol level is low, the machine could suddenly turn off. If this occurs, simply fill it back up with petrol (read §9.4.3).

Let the starter engine run for a while after refuelling. Close the throttle (choke) - the petrol will now be sucked into the line. The engine will start running as soon as the carburettor has filled.

**b. Lack of oil in the engine**

Also read § 9.7.1 under point d.

**c. Machine is on a slope**

Whilst working on a slope in the lengthwise direction, the engine may suddenly stop. This is caused by the oil alarm which works on the basis of level measurement; it detects a false oil level when the machine is in a slanted position. This is enough reason for the system to switch off the engine.

The solution is to wait a few moments before restarting the engine. The problem will return if you continue to do work on an incline. After checking the oil level on an even surface (read § 11.4.1.1.1), the oil safety system may be disengaged temporarily. Do not forget to switch it back on after the work is finished.

Note: Neither ELIET, nor Subaru shall accept warranty claims based on a lack of oil in the machine.

If slopes are a recurring factor in a particular area, adding 0.2 litres of extra oil to the tank will resolve the problem.

**d. Technical defect**

If neither of the aforementioned checks identifies the cause, the problem could be more technical in nature. A defect in the engine or a problem with the carburettor could be the issue. For assistance with these problems, please visit your authorised ELIET dealer or an authorised service centre for the engine brand.

### **9.7.3 Engine loses power**

If you notice that the machine's power reduces for a long period and performance significantly reduces, you must investigate the cause. The following points could be a factor:

- a. Turbine and cutter
- b. Slipping belt transmission
- c. Sparkplugs (Read § 11.4.1.7 Checking or replacing sparkplugs )
- d. Overheating
- e. Problem with fuel supply

- f. Ineffective combustion
- g. Condensation in fuel tank

Run through the above points one by one until you discover the cause of the reduced performance.

#### **a. Turbine and cutter**

The engine output is used to power the hydrostat that provides the drive movement and also to power the turbine and the cutter. That is why it is logical to first check the condition of the turbine and cutter.

#### **b. Slipping belt transmission**

You may also notice the engine losing power as a result of losing traction on the caterpillar tracks or that the cutter and turbine lose power. The reason for this could be that one of the drive belts is slipping. (See § 11.4.3.4).

#### **c. Sparkplugs**

This model of snow clearer uses a 4-stroke/1-cylinder engine. Both cylinders have their own sparkplug which ensures there is ignition for each rotation of the crankshaft. This characteristic ensures that the engine is very responsive and stays up to speed even under loading. If one of the sparkplugs is defective, all of the work will be carried out by one piston and there will be just one ignition per two rotations. This equates to a 50% reduction in power. (See § 11.4.1.7 Checking or replacing sparkplugs).

#### **d. Overheating**

Effective cooling of both petrol and hydraulic systems is vital for optimum functioning. The petrol engine in particular produces a great deal of heat so it is important that there is a good flow of cool air through the engine and within the machine. Loss of power could lead to a lack of cooling. Check the flow of cool air (see § 11.3.3 Cleaning ventilation grilles)

#### **e. Problem with fuel supply**

A small vacuum pump pumps fuel from the tank to the carburettor. This fuel line is equipped with a fuel filter that stops rubbish in the fuel ending up in the carburettor. The filter may become blocked over time and must then be replaced.

- Check the fuel filter (read the relevant procedure in the engine manual).
- Rubbish can build up in a narrowing in the fuel line. Disconnect the line ahead of the fuel filter and blow this out with compressed air.
- Make sure that no rubbish has been taken into the fuel tank. Remove any rubbish by bleeding the fuel via the drainage plug.

#### f. Ineffective combustion

As the engine provides the source of power, it has most influence on efficiency. Optimum engine efficiency is only guaranteed if there is effective combustion. Check whether the choke valve has shut of its own accord as a result of vibration during snow clearing or a lack of maintenance. This means that the supply of fuel to the engine is excessive and leads to incomplete combustion.

This is checked during regular visits to an affiliated ELIET dealer or servicing point for the brand of engine. Request that the following tasks are carried out during every service:

- Carburettor revision
- Ignition check
- Measurement and adjustment of valve clearance



#### Warning:

Ineffective combustion in the engine gives rise to after-burning in the exhaust. This increased exhaust temperature may lead to severe damage to the catalytic converter. Such damage and any subsequent problems with the engine are not covered by the guarantee.

#### g. Condensation in fuel tank

Another possibility is that water has ended up in the fuel tank as a result of condensation. The fact that water is heavier than fuel means that the water sinks to the bottom of the fuel tank. The same phenomenon will be observed on the fuel filter itself. Set the machine on an incline and disconnect the fuel supply line so that the water can be discharged.

### 9.7.4 Blow chute is stuck (no longer rotates)



#### Caution:

The bolts around the blow chute should not be secured tightly. They should be loose enough to be turned by hand.

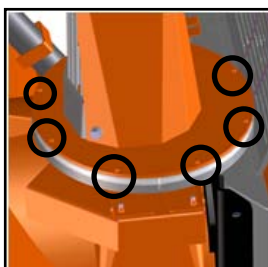

There are a number of possible causes:

a. Blow chute is frozen to the spot

The most likely cause is that the blow chute is frozen in place. Resolve this as follows:

- Stop the machine.
- Move the blow chute manually backwards and forwards so that the ice breaks up.
- Apply anti-freeze and lubricant around the turning area of the blow chute.

b. Empty battery

c. Defective electric engine

d. Defective gearwheel transmission

### 9.7.5 Turbine/cutter is stuck or loses power

You may find that the turbine/cutter becomes stuck as a result of ice, frozen snow or another foreign object. Release the turbine or cutter as follows:

- First turn the ignition key to the STOP position and remove the key.
- Use the special tool with a handle to break up chunks of ice or hard snow.
- Remove foreign objects (sticks, bits of rope,...) that have become lodged around the cutter or turbine.



**Caution:**

Wearing personal protection equipment, i.e. safety goggles and gloves, is mandatory for this task.

## 9.7.6 Moving a machine with a defective engine

The fact that the hydraulic drive pump is powered by the petrol engine means that all hydraulic functions cease to work if the engine is defective. The wheel drive is also hydraulic. Proceed as follows if the 250 kg snow clearer has to be moved and the wheel drive has ceased to function.

- This procedure must be carried out by at least 2 people.
- Undo the locking nut (1) and then undo the bolts (2) on both sides of the hydrostatic pump.

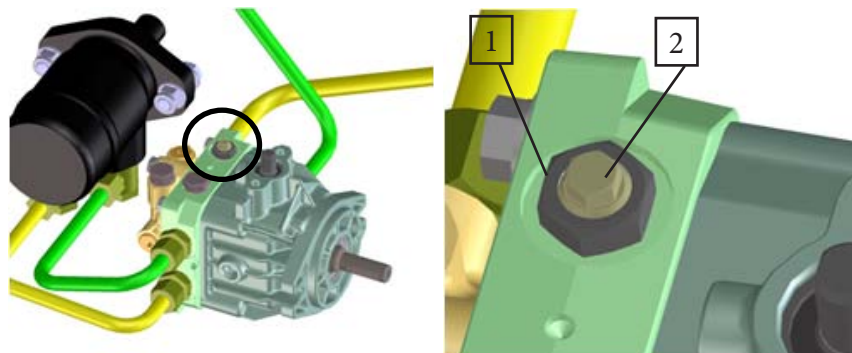

- The machine will be difficult to move in this manner. In addition to the weight of the machine, you will also feel the resistance from the hydraulic drive components.



### Warning:

Never do so if the machine is situated on an incline. The weight may mean that the machine would move down the slope at an uncontrollable speed.

## 9.7.7 Machine deviates from its track

It may happen that when driving straight ahead (joystick vertical position) the machine deviates from its track. The machine is equipped with a differential, this implies that at the slightest resistance difference on the tracks, the differential gives more torque on the track with the least resistance. Following problems may be the reason:

- Tension tracks not equal. For more information, read § 11.4.3.7
- Malfunctioning of one of the hydraulic brakes. Check the brake discs.
- Guide wheel bearings on the tracks of the driving shaft are dirty or worn. Clean, lubricate or replace if necessary.



## 10. Transporting the machine

- Only adults are permitted to move or transport the machine.
- During transport children, unauthorised people or animals must not be allowed within a 5 m radius of the machine.
- Never use the machine for transporting goods or people.
- Carefully choose a clear and free transport path, preferably one with as few obstructions as possible.
- Ensure that the cutter head is in its highest position.
- Lower the engine's RPM for better control of the wheel drive during loading and offloading. This will also reduce the effect of steering errors or loss of grip.
- The transport route is preferably flat, with an even surface.
- Never drive or place the machine on any floor or land surface that cannot support the weight of the machine plus one's own body weight. (for your information: the machine weighs approximately 250kg).
- Use non-slip planks for loading the machine into a van or onto a trailer. Ensure that the planks are properly fastened to the vehicle or trailer.
- The machine weighs around 250kg; make sure that the ramps have the bearing power to carry both the machine and the operator.
- Ensure that the vehicle's handbrake is on.
- A ramp the width of a trailer provides the safest loading/offloading method. It provides support for each point, even if a traction difference on the rollers causes a slight deviation from the straight line.
- If one opts for the classic two planks, each plank must be at least 400 cm wide and must be placed so that both tracks are provided with maximum support.
- Ensure that there is adequate space at the end of the loading ramp (10 m).
- When pushing the machine onto the ramps, keep it in a straight line and avoid steering corrections.
- Under no circumstances should the angle of the incline exceed 15°.
- The maximum permissible lateral incline is 5%.

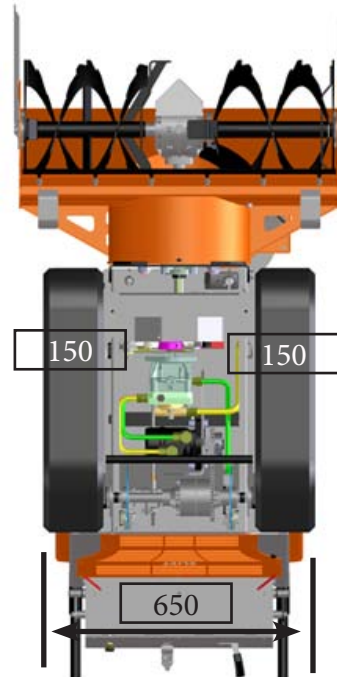

- Work carefully and considerably when loading and unloading the snow clearer in order to avoid it tipping over (350kg) and to prevent an incident turning into an accident.
- When you are going downhill, you must walk backwards with the machine in front of you.



**For your information:**

the weight of the machine means that it could suddenly begin to move faster when going downhill. If this occurs, ensure there is a sufficient run-off area behind the loading plates (10 m).

- Ensure that the vehicle/trailer is not overloaded. The snow clearer weighs around 250kg.
- Make sure the machine is properly attached in the vehicle during transport. Attach ropes, belts or tensioning ties to the fixed chassis parts to secure the machine.
- The ropes, belts or tensioning ties used must be in a perfect condition and capable of sustaining a tensile load of 500 kg.



**Warning:**

Never run the machine for more than 30 seconds in a closed environment where animals or people are present. Exhaust fumes from petrol engines contain toxins that can cause poisoning or suffocation.

- Do not run the engine longer than necessary when (off)loading the snow clearer into/from a closed van. Open all the doors of the loading area to ensure sufficient ventilation.



**For your information:**

Always close the petrol tap on the machine before transport. Failure to do so may result in excessive amounts of petrol being fed into the engine, causing starter problems and the risk of having to change the spark plug.

- Machine breakage or defects resulting from incompetent operation are excluded from the warranty conditions.

# 11. Maintenance



## 11.1 General



### For your information:

The dealer and his staff are readily at your service and you can also rely on the ELIET help desk for support. This combination guarantees you the best joint effort to find a solution to any problems you may have. For repairs or maintenance you can turn to your authorised ELIET dealer or a service centre authorised by the engine manufacturer. Please always submit the model and serial numbers of the machine and the engine, as well as a complete description of the problem.



### Caution:

Use only genuine ELIET or B&S Vanguard spare parts when performing repairs. These service parts are manufactured according to the same strict quality requirements and craftsmanship as the original equipment.

- Maintenance or repairs that are not described in this manual must be performed by an authorised ELIET dealer.

Perform maintenance in a room intended for this purpose. The area must meet the following criteria:

- Spacious
- Easily accessible
- Well lit
- Dust-free
- Clean and tidy
- Quiet

These characteristics are important to properly carry out maintenance tasks.

**Caution:**

Maintenance performed in an incorrect manner may compromise the operator's safety.

- Maintenance should be always carried out with the engine turned off. Turn the ignition key to the OFF position and remove the key from the ignition.
- Wear safety gloves as much as possible when performing maintenance. Safety goggles may be required for certain operations.

**TIP:** In principle, the maintenance work described may be carried out by any person with technical skills. However, ELIET recommends that the machine be brought to an authorised ELIET service centre for a major overhaul each year.

Your ELIET dealer is always ready to carry out maintenance and provide advice. He stocks genuine ELIET replacement parts and lubricants. His staff can always obtain advice and service from ELIET's help desk in order to provide you with impeccable after-sales service.

## 11.2 Maintenance schedules

---

### 11.2.1 Periodic maintenance schedule

**Each work session**

Clean the machine  
 Visual inspection  
 Oil level check  
 Check the oil level of the hydrostat  
 Check ventilation grilles

**Every 25 hours**

Change the engine oil  
 Check belt tension  
 Check spark plugs  
 Lubricating chains  
 General lubrication treatment

**Every 100 hours**

Replace spark plugs  
 Replace tensioning rollers  
 Replace slip coupling  
 Tensioning chains

**Every 200 hours**

Replace belts  
 Replace bearings

**Every 500 hours**

Change hydrostatic oil  
 Replace hydrostatic filter

**Lubricants**

Engine	SUNOCO DENALUBE SAE 20W50 API SF / CC
Hydrostatic	SUNOCO Sunvis 846 WR HV
Bearings	NOVATIO PTFE OIL
Hinges	NOVATIO CLEARLUBE
Cable guides	NOVATIO PTFE OIL
Grease nipples	SUNOCO MULTI-PURPOSE GREASE LR - EP2
Chains	NOVATIO CLEARLUBE & PTFE OIL

**11.2.2 Opening the Snowbob's upper casing**

- Hold the casing at the front of the machine and tilt it upwards. The casing is equipped with a damper which makes the upward movement easier and keeps the casing in the raised position.
- The casing is closed by pressing it downwards.



### 11.2.3 Dismantling safeguards on the side of the machine

- The upper casing must first be raised before removing the side covers.
- The bolt connectors on the side of each protective cover can then be removed.
- Tilt the cover slightly towards you and remove the cover from the machine frame.
- Follow the same steps in reverse order to close the cover. The recesses in the underside of the cover must be fitted over the pins on the frame.

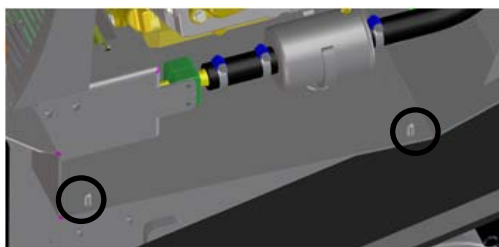
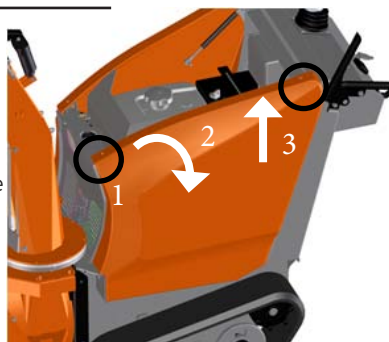

## 11.3 Cleaning the machine

### 11.3.1 The importance of cleaning

ELIET recommends cleaning the machine after each use. We recommend performing an inspection each time you clean the machine to check component and machine integrity. It allows timely intervention and prevention of any defects, ensuring a longer service life of your machine.

Not cleaning the machine will lead to:

- Increased wear
- Increased risk of fire
- Reduced performance
- Illegibility of safety stickers
- Not noticing defects or wear at an early stage

#### **Caution:**

Failure to perform the daily [sic] cleanup will result in loss of warranty.

**Warning:**

Any suboptimal performance of the machine can compromise the operator's safety.

**Caution:**

Wear suitable clothing for cleaning activities. Utility gloves are essential.

### **11.3.2 What does cleaning entail?**

- Cleaning the machine entails more than just cleaning the outside. Open all protective covers so that you can also clean the inside of your machine.
- Check the entire machine when cleaning and subject it to an inspection if required. Check that no parts have been deformed, that welded seams are not cracked and that parts are not excessively loose.
- Any necessary replacement and/or repair works must be undertaken immediately. Visit your authorised ELIET dealer to have them carried out (find an authorised ELIET dealer near you on [www.eliyet.eu](http://www.eliyet.eu)).
- The following points require special attention:
  - o Check for any damage to visible electrical cabling, electrical connectors and switch components.
  - o Inlet and outlet openings for cool air (read § 11.3.3)
  - o Battery
  - o Zones around turbine/cutter bearings
  - o Hydraulic vents and quick connectors
  - o Rubbish (snow residue, sticky detritus) inside the machine must be removed. Use a soft brush, dry cloth or vacuum cleaner to remove this dirt.
  - o Particularly where safety stickers have been placed. (Do not use a cleaning agent that will remove paint or stickers). Any stickers that are no longer legible must be replaced. Original stickers can be purchased from your ELIET dealer.
- Use penetrating oil on MoS2 basis to remove dirty grease and lubricants. This spray is a lubricant and rust solvent at the same time.
- After removing dirty lubricant it is important to reapply new lubricant in order to guarantee the proper functioning of the machine. (A list of recommended lubricants is included in Appendix B).
- Compressed air can be used to easily blow out and clean some parts.

**Caution:**

Compressed air can damage the water-tightness of certain electrical components!

- A vacuum cleaner is sufficient for removing dirt even if it is located at hard-to-reach locations.

**Warning:**

If you must remove the protective cover in order to perform maintenance, make sure you replace this correctly thereafter. Safeguards are there to protect you.

### 11.3.3 Cleaning ventilation grilles

For safety reasons and noise considerations, the mechanical 'heart' of the machine is fully encased by large protective covers. The functioning of the mechanical components goes hand in hand with the production of heat (engine, hydraulics, belt,...). Cooling is therefore vital and it is important that there is a sufficient flow of cold air around the machine. See the cool air-flow on the following diagram.

Check whether the suction opening for the cool air is free from blockages.

See the cool air-flow on the following diagram.

- Check whether the suction opening for the cool air is free from blockages.
- Make sure that the engine's cooling fins are not blocked.
- Make sure that the exhaust openings for hot air are not blocked.
- Make sure there are no accumulated snow residues that could hinder cooling of the structure and the hydraulic components.





## 11.4 Maintenance procedures

### 11.4.1 Engine maintenance

#### 11.4.1.1 Checking level and refilling engine oil

If the oil level in the engine drops below a certain level, the electronics in the machine will go into safe-mode and the engine will switch off. By then, the machine will have been working with a lack of lubrication for some time. In order to avoid this scenario, regular checks on the oil level are vital.

- Place the machine on flat ground so that the engine plate is horizontal.
- Turn the engine off and take the key out of the ignition.
- Leave the engine to cool down for about 15 minutes.

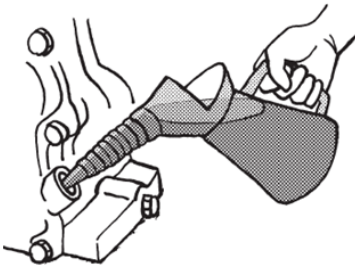
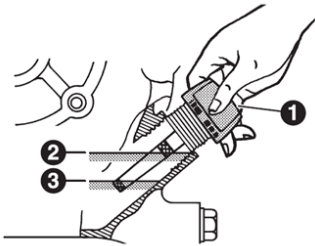

- Open the 3 protective covers around the engine.
- Remove the filler cap (1) with the dipstick attached to it from the crankcase.
- You will then be able to see if there is enough oil in the crankcase. The oil level should come up to the brim of the filler opening. The oil on the dipstick should touch the maximum mark.
- If the oil tank is not filled to the brim, this indicates a lack of oil.
- It suffices to add some oil via the filler opening until the proper level has been reached. Continue to add oil until the desired level is reached.
- Since the location of the filler opening is in a somewhat awkward position, we recommend the use of a tube or special funnel to avoid oil spills.



#### Caution:

- Be aware that it will take a while for the oil to fully descend into the sump. Make sure you leave small intervals when filling the oil so that the dipstick gives the correct oil level reading.
- Oil shortages cause severe, irreparable engine damage. (This type of defect is not covered under warranty).

### 11.4.1.2 Changing the engine oil

- In order to drain the oil, place the machine on flat ground so that the engine plate is horizontal..
- As a precaution, remove the key from the ignition.
- Open the 3 protective covers around the engine.
- Clean the area around the oil filler cap on the other side of the engine and unscrew the cap, allowing the crankcase to vent while emptying the tank.
- Unfold the drainage hose and position a receptacle with a 2l capacity under the end of the hose.
- You can unscrew the cap of the hose with 18 and 22 spanners; the dirty oil will then run out of the engine. Once all of the oil has run out of the machine, secure the cap of the drainage hose once again. Then click the drainage hose back into its holder.
- Fill up with about 1.2l of oil and then replace the Snowbob on level ground. Wait for a short while before checking the oil level and, if necessary, fill further.
- Once filling is complete, do not forget to replace the oil filler cap.

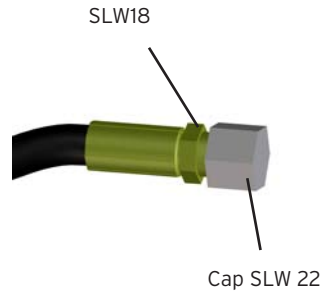
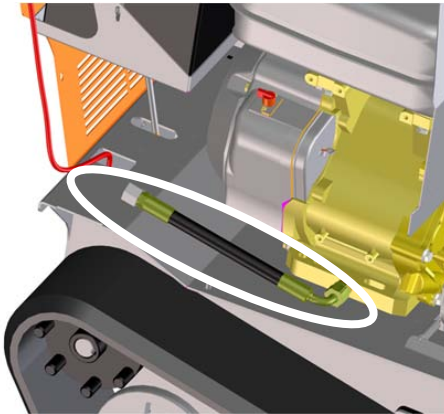

#### Warning:

Respect the environment: take the oil to an authorised collection point for expert processing or recycling. Never pour oil down the drain.

### 11.4.1.3 Checking and/or changing the spark plug

The type of snow clearer is equipped with a two-cylinder engine. This means that it has two sparkplugs. These are screwed into the cylinder head.

The sparkplug is a crucial component which plays a significant role in determining combustion efficiency. You must therefore check the sparkplugs after every 50 hours of use.



#### **For your information:**

Read the engine manual thoroughly.

- Turn the engine off and leave to cool down. Remove the key from the ignition.
- Remove both sparkplug caps from the sparkplugs.
- Clean the area around the spark plug and remove the spark plug from the cylinder head. (SW 13/16")
- Using a feeler gauge, check whether the distance between electrodes is 0.8 mm.
- If necessary, bend the side electrode carefully until the correct distance has been reached.
- The sparkplug must be replaced if it shows heavy deposits or is very dirty.
- Sparkplugs must be replaced after 200 working hours.



#### **Caution:**

Replacing an old sparkplug or putting in a new one must be done with utmost caution, avoiding any possible damage to the screw thread in the cylinder.

- Secure the sparkplug with a torque of 20 Nm.

## 11.4.2 Maintenance on the hydrostatic pump

### 11.4.2.1 Changing hydrostatic oil and oil filter

Even though the hydraulic circuit is closed, the hydraulic oil will get dirty. This dirt is continuously filtered via a hydraulic filter. When this filter becomes dirty, the oil flow will reduce and cavities may occur. It is therefore advisable to change the oil and filter every 500 hours. For this, proceed as follows:

- Place the machine on a flat ground so that the engine plate is horizontal.
- Turn the engine off and take the key out of the ignition.
- Have a collection reservoir ready with a volume of at least 6l.
- Open the filler cap on top of the tank.
- Now unscrew the pump's drainage plug on the base of the machine without undoing it completely. Use a 19 mm wrench.

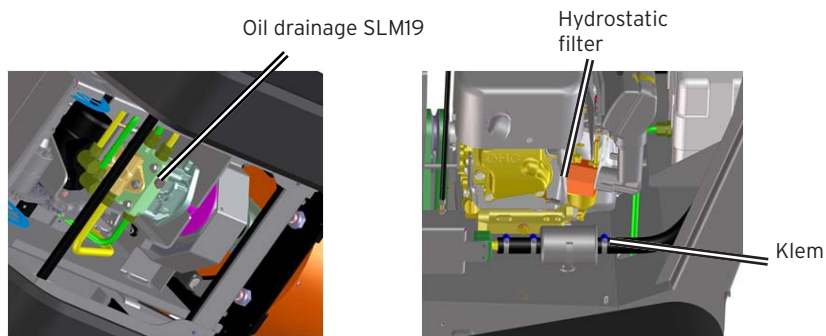

- Empty the full contents from the engine. Make sure that all oil is properly collected in the receptacle.
- Once emptied, the oil filter can be replaced. Undo the 2 clamps and remove the filter. Replace with a new one.



#### Caution:

Check to ensure that the new filter has been installed correctly, according to the flow direction.

- After replacing the filter, screw back the drainage plug
- Clean away the spillt oil with a clean cloth.

- Remove the collection reservoir.
- Now pour xx litres of fresh hydrostatic oil into the tank. ELIET recommends high quality oil.
- Close the reservoir.
- Start the engine and move the machine a few metres.
- Check the oil level once again and top up if necessary.



**Warning:**

- Oil shortages in the hydrostatic pump inevitably cause severe damage. (This type of defect is not covered under warranty).
- Respect the environment: take the oil to an authorised collection point for expert processing or recycling. Never pour oil down the drain.

### **11.4.3 Machine maintenance**

#### **11.4.3.1 Visual inspection**

It is essential before commencing the work that the machine undergoes an inspection. This will allow you to anticipate breakage or wear and tear that affects the life span of the machines.

- Check whether the machine operates at the proper rotational speed at full throttle (3,200 RPM)
- Try not to change the standard settings for the engine.
- Check that no parts have been deformed, that welded seams are not cracked and that parts are not excessively loose.
- If problems are found, carry out the necessary repairs or maintenance first.

Consult your authorised ELIET service centre for assistance if necessary or to obtain replacement parts. Find an ELIET service centre nearest you at [www.elieta.eu](http://www.elieta.eu).

### 11.4.3.2 General lubrication treatment

ELIET is committed to using high-quality materials that extend a machine's life cycle despite the sometimes extreme work circumstances in which snow clearers are used. For this reason, special lubrication products have already been applied in the factory. ELIET also recommends lubricating all parts on a regular basis:

- Bearings
- Hinges
- Friction areas



**Caution:**

As applies to all maintenance work, the engine must be turned off here as well. Remove the key from the ignition.

A. Lubrication via lubrication nipples

1. Cutter bearings

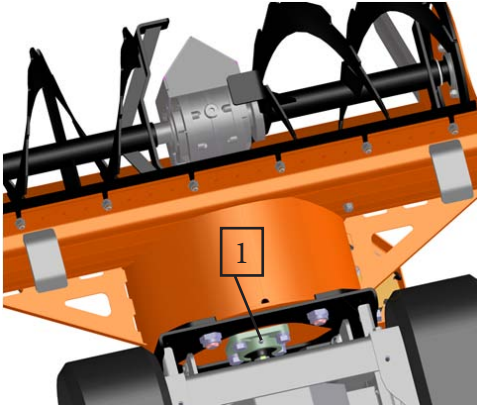

Follow this procedure:

- Clean the lubrication nipple.
- Spray on new grease in the lubricating nipple using an altered grease dispensing lever.
- ELIET recommends Sunoco Multi Purpose Grease.
- One or two pump-fulls will suffice to redistribute the new grease.
- Remove the grease that protrudes via the seams.

**Caution:**

Be careful when spraying new grease into the ball bearings.  
The pressure that is built up with the spray could tear cap seals.

## B. Lubricating bearings

1. Bearings Cutter (2x)
2. Bearings pulley caterpillar tracks (2x)
3. Reciprocating roller bearings (4x)
4. Belt transmission tension rollers (2x)

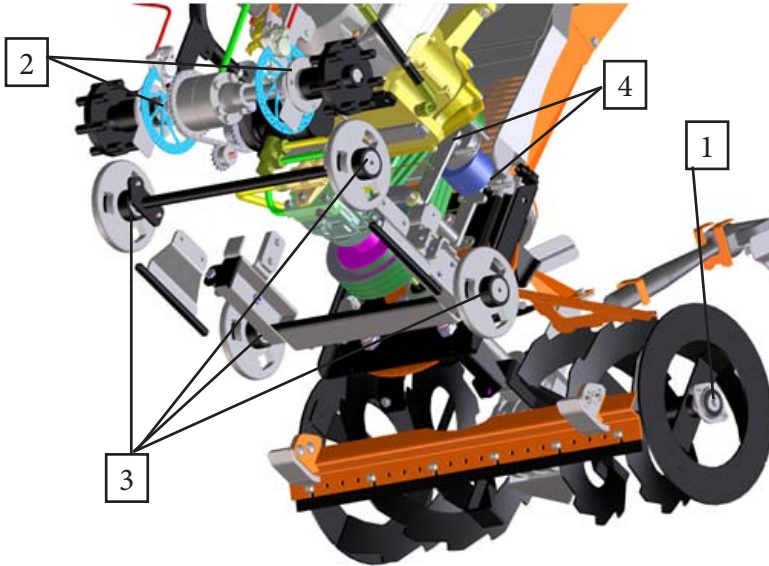

Follow this procedure:

- Use a duster to remove all dirt that has adhered around the bearing seams.
- Spray the penetrating oil into the seams of the bearing seals again so that the oil can penetrate the bearings.
- All excess spray should be removed.
- Spray Novatio White Supreme Grease into the seams of the bearing seals.

### C. Lubricating hinges

This group encompasses the following points on the machine:

1. Hinges (ball joints and hinges) handlebars
2. Hinges for cutter head height regulators
3. Hinges protection cover
4. Hinges directional valves
5. Hinges tension rollers belt transmission

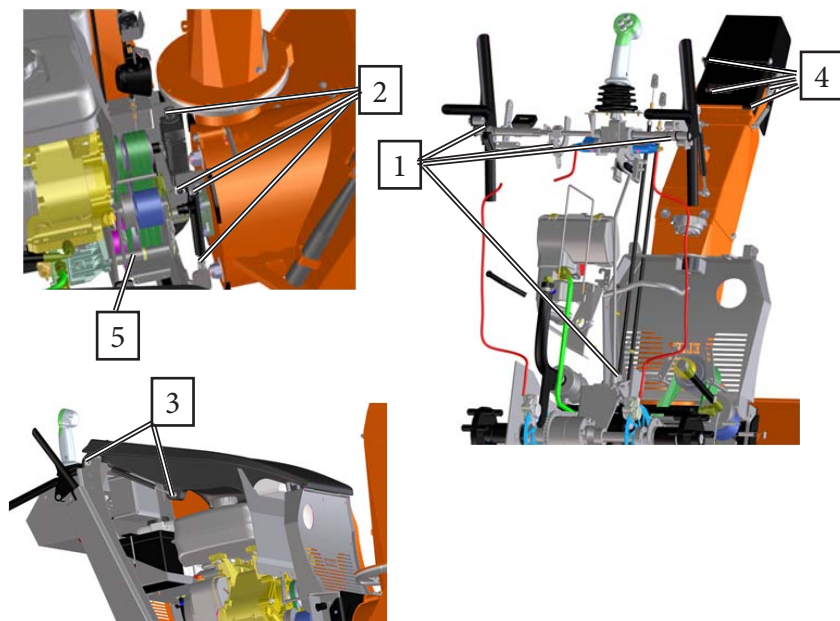

Follow this procedure:

- Where possible, disassemble the hinge or joint.
- Spray the chafing parts with a molybdenum disulphide (MoS<sub>2</sub>) -based penetrating oil, and allow it to seep in evenly.
- Wipe off all the old excess grease and other dirt sticking to the area.
- Use compressed air to get rid of all other dirt in harder-to-reach areas between the hinge joints.



#### D. Lubricating the chain and chain wheels

The chain grease applied will have worn away after a few hours, or will be cluttered with dirt and debris. To prevent wear and tear on the line shaft, you will need to apply lubricant regularly. The machine has one Simplex chain for the transmission between the left front roller and the back roller and the rotating drum in the seed container.

- The rear protective cover must be removed for this maintenance. These 6 bolts can be loosened with an Allen key number 4.
- We recommend cleaning the chain and wiping away the old lubricant that will inevitably contain dust, before applying new lubricant. The use of KLEENSPRAY may help to soak off and dissolve any old grease.
- Wipe away any old grease before applying new lubricant.
- So as to prevent the lubricant from wearing away too quickly due to the rotation of the line shaft or the gravitational pull of the line, we opt for a less viscous and more adhesive oil.
- Since both the chain inside and the contact surface with the gears need to be lubricated, ELIET recommends using a combination of two lubricants.
- NOVATIO PTFE OIL is very viscous and will easily penetrate the chain links.
- NOVATIO CLEARLUBE, a more viscous oil, will cling to the outside of the chain. This lubricant diminishes the friction between the chain and the gears.
- When replacing the protective cover, ensure proper closure to keep the inside free from dust.

#### E. Friction areas

Friction surfaces include all machine parts that are subject to wear from lateral friction with other parts. Here, too, the aim is to apply a film of lubricant between the rubbing parts that will reduce movement resistance, minimise wear and repel water. These surfaces include:

1. Cable guides cutter controls
  2. Cable guides speed control engine
  3. Cable guides dead man's handle
- Proper functioning of the control levers is crucial and regular lubrication of the cables is therefore of vital importance.
  - Prior to lubricating, the cables must be cleaned. KLEENSPRAY is again an ideal tool.
  - Also spray it into the cable guide and simultaneously move the cable back and forth to ensure that the cleaner penetrates the guide.
  - Use compressed air to clean the cable guide of both cleaner and dirt.

- Repeat this procedure until the guides are completely clean.
- New lubricant may now be sprayed into the guide. ELIET recommends NOVATIO PTFE OIL. All lubricants indicated are available from your authorised ELIET dealer.

In addition to the cable guides, the following parts also need regular lubrication:

4. Gearwheel transmission rotating blow chute
5. Piston rod - actuator directional valves
6. Piston rod - actuator rotating movement of cutter head
7. Piston rod - actuator height regulator of cutter head

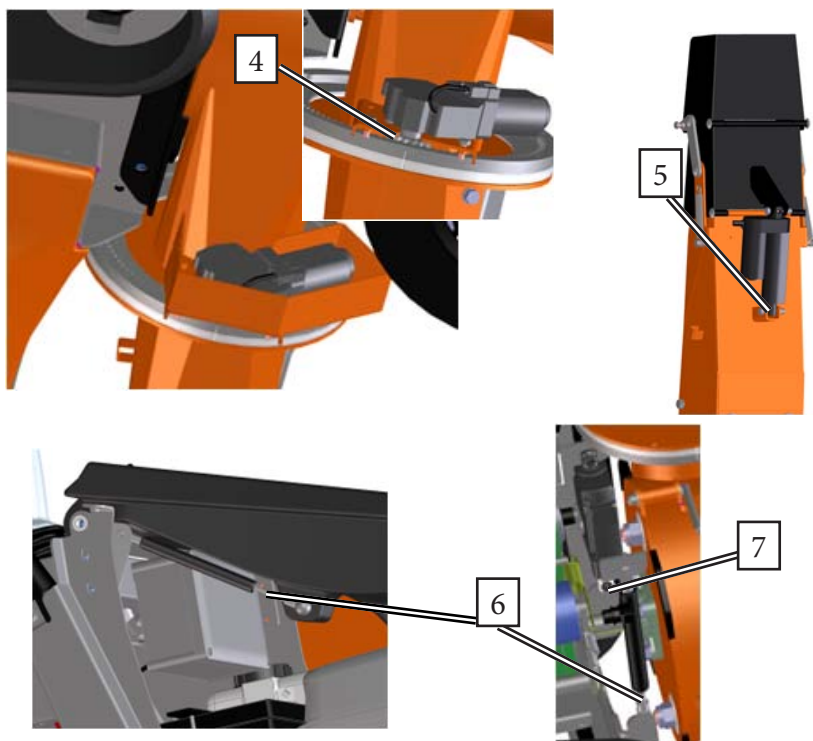

- The procedure is the same for all other friction surfaces mentioned earlier: first loosen old lubricant with KLEENSPRAY and wipe it away.
- Then spray NOVATIO PTFE OIL on the friction part.
- After lubricating, all protective covers must be replaced.

### 11.4.3.3 Adjusting cable guides

- Turn the engine off and take the key out of the ignition.
- Tilt the machine's protective cover upwards and remove the side covers
- Check that all levers are set to neutral.
- Remove the M8 lock nut (13 mm spanner) and rotate the control guide counter-clockwise a few times (=tension cable guide) or clockwise (=loosen cable guide). Use a (11 mm) spanner if necessary.
- Once set, tighten the lock nuts so that this cannot become dislocated as a result of vibration.

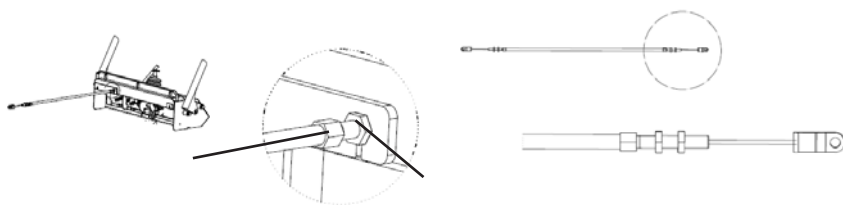

### 11.4.3.4 Belt tension check and adjustment

The machine incorporates 3 green belts for the cutter drive and 1 black belt for the hydrostatic drive.

After a few work hours, these belts become elastic and lose tension. Insufficient tension on these belts means that the belts will slip under loading, increasing wear and tear and reducing the belt's life span. A belt that is insufficiently tensioned will flap around, increasing the chance that it will come off the belt pulley. Belt tension must, therefore, be checked regularly (every 25 work hours).



#### **Caution:**

Tension a new belt for the first time after a running-in period of 10 work hours.

- As with every other aspect of maintenance, you must turn the engine off and remove the key from the ignition.
- Tilt the machine's protective cover upwards and remove the side covers.

### Cutter drive belt tension

These three belts are tightened with a flat tensioning roller that is pulled against the back of the belt when pressing down the cutter operation lever.

- If the belt starts to make a squeaking sound or if the resistance on the operation lever is too low, then this is a sign that the belt tensioning roller needs to be adjusted.
- You will know that you have reached the proper amount of tension if, just before fully pressing on the lever (20 mm of play up to the handle), the belt tensioning roller is already pressing against the belt and begins to tug onto the spring.
- If this is less than 20 mm, then the force of pressure from the tensioning roller will need to increase by adjusting the length of the starter cord.
- The cable guide provides two control options. One close to the lever and one near the belt drive. For more information on adjusting cable guides, see § 11.4.3.3.

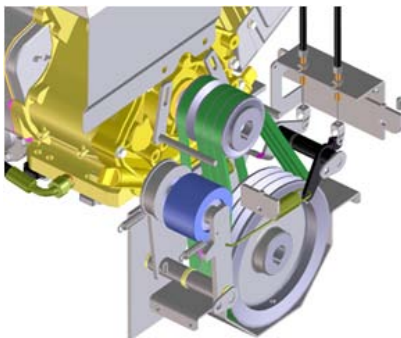

#### Caution:

The cutter should not turn if the lever is in its idling position (not powered).

- Check to ensure that the distance between the turns of the tension spring when the lever is in an idling position is 1mm.

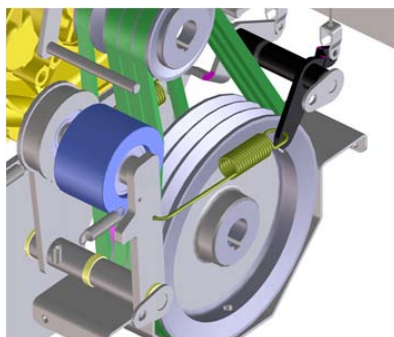

- Once set, the protective cover can be replaced.

### Belt tension of hydrostatic drive (black belt)

- If the belt starts to make a squeaking sound or if the resistance on the operation lever is too low, then this is a sign that the belt tensioning roller needs to be adjusted.
- The back plate of the machine must be removed in order to access the hydrostat's speed control belts. These 10 bolts can be loosened with an Allen key number 4.
- The required belt tension is obtained when, if the corresponding operation lever is held at a distance of around 20mm from its maximum position, the tensioning roller already presses against the belts and begins to pull on the spring.
- If this is less than 20 mm, then the force of pressure from the tensioning roller will need to increase by adjusting the length of the starter cord.
- Check to ensure that the distance between the turns of the tension spring when the lever is in an idling position is 0.5mm.

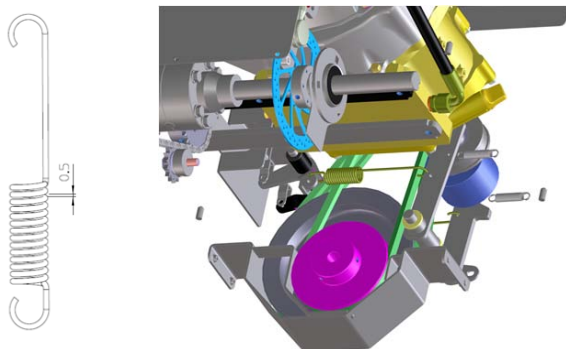

#### 11.4.3.5 Replacing belts

- As with every other aspect of maintenance, you must turn the engine off and remove the key from the ignition.
- Check to ensure that the distance between the turns of the tension spring when the lever is in an idling position is 0.5mm.

### Cutter drive belt tension

- Loosen both belt catchers by unscrewing the M8 bolt (spanner size 13) so that the belt holder can be tilted aside.
- Replace the belts with belts of a similar type and length. (type xxx)
- The cutter should not turn if the lever is in its idling position (not powered). For more information about adjusting, you are referred to § 11.4.3.4.
- After putting the belts back on, the belt catcher needs to be replaced so as to prevent the belts from coming off when decoupling. They should be put on such that there is about 5mm remaining between the pulley and belt catcher.

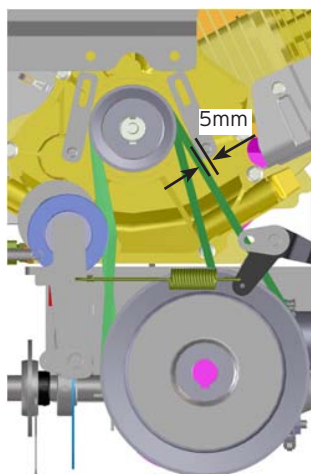
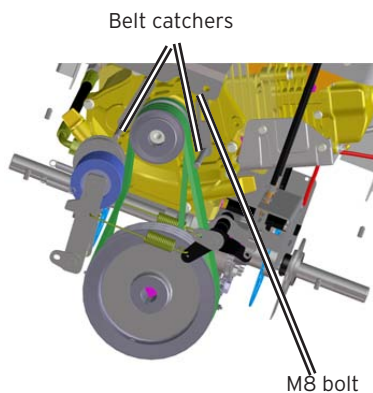

### Hydrostat speed control belt tension

- To change this belt, the 3 belts must first be taken off the cutter drive (see above).
- Then loosen both belt catchers by unscrewing the M8 bolt (spanner size 13) so that the belt holder can be tilted aside
- Replace the belts with belts of a similar type and length.
- The pump should not turn if the lever is in its idling position (not powered). For more information about adjusting, you are referred to § 11.4.3.4
- After putting the belts back on, the belt catcher needs to be replaced so as to prevent the belts from coming off when decoupling. They should be put on such that there is about 5mm remaining between the pulley and belt catcher.
- After calibrating and testing the belt tension, replace the protective covers.

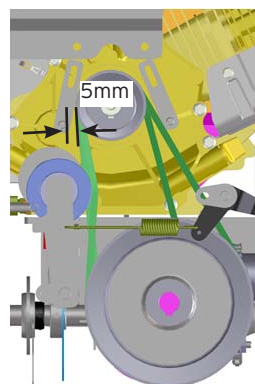

### 11.4.3.6 Setting cutter plate

- Place the machine on an even, paved surface (e.g. concrete or asphalt, etc.).
- Turn off the engine.
- Partially loosen the 2 skid shoes by undoing the 2 M8 bolts per shoe.
- The 7 M8 bolts on the blade under the cutter head must then also be undone (not fully).
- Turn the ignition on without starting the engine. This enables the position of the cutter head to be controlled.
- Lower the cutter head until a space of 5mm has been reached on both sides between the frame of the cutter head and the ground.
- Lock this position by pushing both skid shoes onto the ground and then securing with the M8 bolts.
- The blade is then positioned so that there is a margin of 2mm; the blade is then secured with the M8 bolts.



#### **For your information:**

It may be handy to secure the outer bolts first and then set the cutter head to its highest position before securing the other bolts.

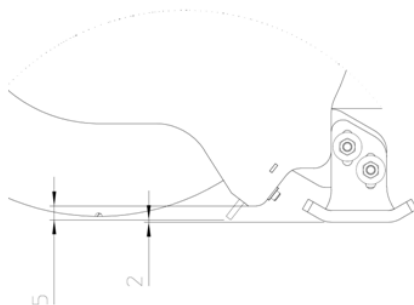
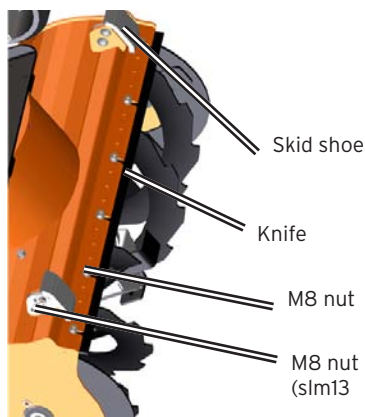

### 11.4.3.7 Adjusting caterpillar track tension

- Place the machine on an even, paved surface (e.g. concrete or asphalt, etc.).
- Turn the engine off and take the key out of the ignition.
- First, partially loosen the 2 M10 locking bolts (spanner size 17).
- Then loosen the M10 lock nut (spanner size 17).
- The front guide wheel can now be moved forwards by turning the M10 control bolt (spanner 17). This will tension the caterpillar track.
- Caution: you must always be able to depress the centre of the track (between guide wheel and drive wheel) by x cm. If not, make the appropriate adjustments.
- Once the caterpillar track tension is set correctly, tighten the lock nut and the 2 locking bolts.
- Repeat this process for the other caterpillar track.

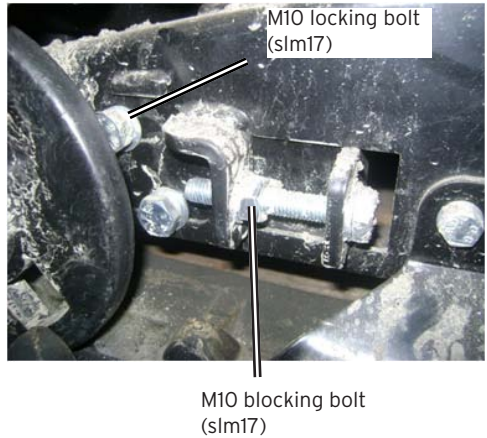
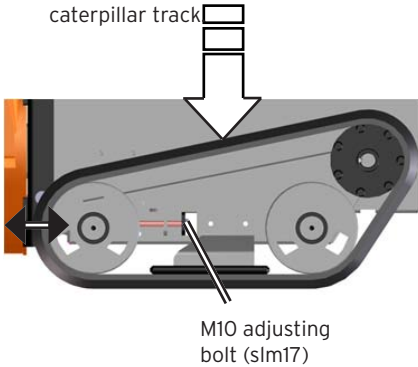

### 11.4.3.8 Setting cruise control

The joystick is designed so that it returns to the neutral position by itself when it is released; this then brings the machine to a halt.

If a set speed must be retained during movement, the Joystick must therefore be constantly held in a particular position. This means that the arm and wrist must be held in the same position for long periods when working. This can lead to cramps or weariness. To avoid this, a cruise control has been provided on the machine.

This function ensures that the Joystick movement becomes stiffer when going forwards or backwards and does not return to the neutral position of its own accord. As a result, the Joystick retains its position and allows the machine to continue at a fixed speed without being actively operated.



How to set it up:

- Loosen the 2 bolts on the brake blocks and slide these against the blade.
- Ensure that both brake blocks press against the blade with equal pressure and then re-tighten.
- Check to make sure that the joystick is in a vertical position when releasing the joystick. If this is not the case, the machine will deviate from its line when working.

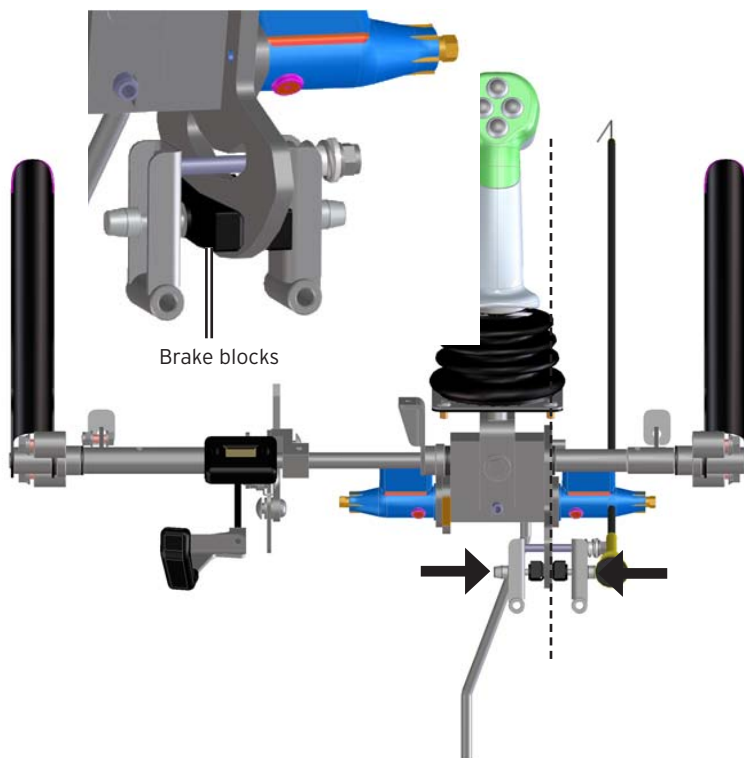

### 11.4.3.9 Replacing brake blocks - hydraulic disc brakes

Brake blocks are subject to wear and tear. It is, therefore, important that you regularly check the thickness of the brake blocks.

- As with every other aspect of maintenance, you must turn the engine off and remove the key from the ignition.
- In order to access the disc brakes, the rear plate of the machine must be removed. These 6 bolts can be loosened with an Allen key number 4.

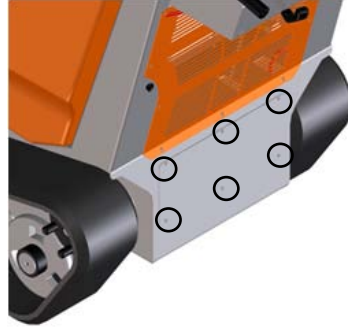

Check:

- When engaging the brake (central joystick moved towards the brake) check whether the feeler on the (yellow) transport lock can be placed in between the “ears” of the brake blocks.
- If this is not the case (see diagram), the blocks must be replaced. Always replace both brake blocks at the same time!
- The minimum thickness of the blocks, including holder, must be 2.5mm.
- If the transport lock's feeler fits between the brake blocks when engaging the brake, the brake blocks are ok.

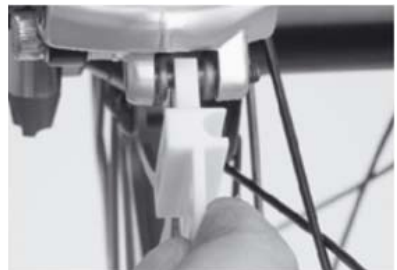

Replacing:

- Dismantle the brake calliper by removing the 2 M6 bolts using the size 10 spanner.
- Remove the lock
- Gently remove the brake blocks on the underside of the brake calliper.
- Only replace with original Magura brake blocks.



Note:

- Never depress the pistons if brake blocks have not been fitted as this could cause damage.
- When installing new brake blocks, the friction area must face inwards, towards the disc.
- Then replace the lock
- Replace the brake calliper in the usual place
- Then engage the brakes several times (pump them) until the brake blocks set themselves and a fixed pressure point is reached.

#### 11.4.3.10 Lubricating and tensioning chain

The machine has 1 chain drive, that being the transmission between the hydrostatic engine and the differential.

Its capacity and RPM are very limited, hence the choice for a single (simplex) chain.



#### **Caution:**

Never tighten the chain too tightly. Too much driving capacity would be required as a result, leading to extra wear of the chain and sprockets. Furthermore, a high radial tension can harm cap seals and bearings.



#### **For your information:**

When checking the chain tension, also check the chain and the sprocket for extensive wear. If the teeth are worn the sprockets and chain must be replaced. Visit your authorised ELIET dealer for assistance.

**For your information::**

Use this maintenance moment to lubricate the chain (read § 11.4.2.3).

**Caution:**

As with every other aspect of maintenance, you must turn the engine off and remove the key from the ignition.

**Caution:**

Always wear suitable clothing for performing this type of maintenance.

- The chain is subject to loss of elasticity after time and it will start to hang loose, with a risk of jumping off the gear under heavy strain. If you notice that the chain is loose when performing lubrication maintenance, then it will require tightening.
- Remove the protective cover on the back of the machine.
- The chain can be tensioned easily by raising the chaintensioner.
- To do so, loosen the (M10) nut that holds the chain tensioner to the frame. Use a 17 mm ring spanner.

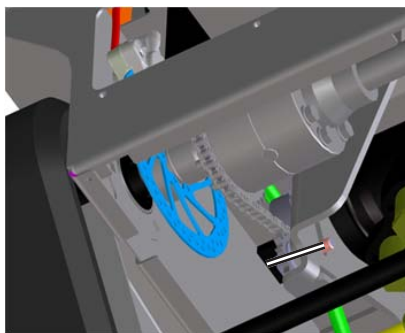
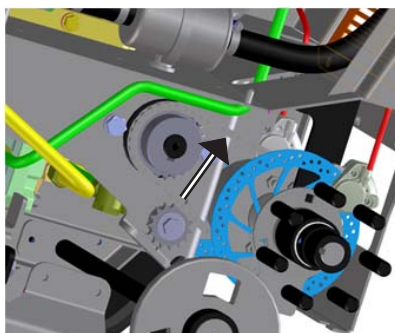

- Move the spanner upwards.
- Caution: over-tightening the chain can lead to accelerated wear of the bearings and the chain.
- Re-tighten the (M10) nut that holds the chain tensioner to the frame.
- Carefully replace the protective cover and fasten it.

### 11.4.3.11 Replacing chains

The chain is equipped with a chain joint that makes the chain easy to dismantle.

#### Dismantling

Follow this procedure:

- Remove the spring clip (C).
- The chain can now be taken apart by removing the side plate with pin (A) and the side plate (B).

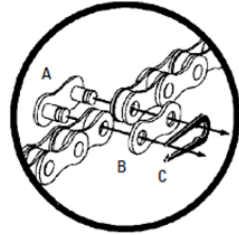

#### Assembly

- Replace with the same type of chain (xxx)
- Bring the ends together and connect with the chain joint. This comprises a side plate with pin (A), a side plate (B) and the spring clip (C).
- Secure the side plate with pin (A) to the ends of the chain, place the other side plate (B) on this and press on the chain joint (A+B).
- Place the spring clip on top; the closed end of the spring clip must point in the chain's rotational direction.
- Secure the spring clip in the grooves of the pin by sliding the spring in the direction of the X arrow.

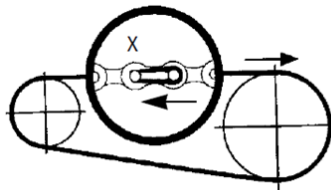

- Set the chain. See above
- Close all protective covers.

## 12. Winterizing the machine

---



- Clean the machine (read § 11.2.1; p.45).
- When winterizing the machine for long periods, it is recommended to perform the following steps:
  - Conduct a major overhaul (read § 11.3; p.48).
  - Check all nuts and bolts for correct tightness, and where necessary, retighten them.  
Drain the fuel tank.
  - Repaint areas with damaged paint or cover with grease in order to prevent rust.  
Original ELIET paint in the same colour is available from your ELIET Dealer.
  - Store the machine in a dry place that is protected from rain, and if necessary, cover it with a tarpaulin.
  - Always allow the machine to cool down before storage.
  - If the machine is to be stored outside, it must be well protected with a tarpaulin.  
Ensure that water does not directly fall onto the machine. At ELIET, we strongly recommend that the machine is stored at a location that is well protected from the weather, etc.

# 13. Technical data



Engine selection .....	Subaru EX40
Power KW/PK DIN: .....	10.3/14
Revolutions .....	3.600 rpm
Engine starting system .....	Electrical
Working width .....	810 mm
Working height .....	550 mm
Working capacity .....	70T/h
Ejection distance .....	17 m
Cutter unit .....	Hardox steel
Cutter drive .....	slip coupling
Depth setting cutter head .....	electrical
Cutter head inclination .....	Pos. A = fixed - Pos.B = free oscillating
Setting chute .....	electrical 220°
Direction valve operation .....	electrical
Drive speed (forwards - backwards) .....	4 km/h < 0 > 4 km/h.
Control .....	Joystick (All-in-one™ Control)
Drive .....	Hydrostatic
Transmission .....	continuously variable
Hydraulic steering .....	Brake
Undercarriage .....	Caterpillar tracks
Track width .....	150 mm
Track length .....	665 mm
Lighting.....	55 W
Options	
.....	Eliet HotSpot™ Heat supply operator's position
.....	Tempostat
Dimensions (LxWxH) .....	1540 mm x 810 mm x 1430 mm
Weight .....	250 kg

## 14. EC-Declaration Of Conformity - SNOWBOB

---

Machine: **SNOWBLOWER**  
Type: **ELIET SNOWBOB 8014T**  
Model number: **MA 023 040 439**

The previously mentioned machine has been designed and manufactured to comply with the following European CE regulations :

### **EN 15059: "Snow grooming equipment - Safety requirements"**

ELIET mfg. cy. hereby declares that after performing a hazard analysis, it is fully aware of the potential hazards and risks associated with the machine. In this knowledge, the necessary steps have been taken in line with Machine Directive 2006/42/EC in order to ensure absolute operator safety for the operator, when the machine is used correctly.

The value of the measured sound power level and the guaranteed sound power level were obtained according the procedures set forward in the directive 2000/14/EG annex III/B clause 51 and directive EN 15059.

Measured sound power level L<sub>WA</sub> : dB(A)  
Guaranteed A-weighted sound power level : dB(A)

Date: 01/01/2011  
Signature:



Frederic LIETAER  
Managing Director ELIET EUROPE NV  
Date of birth: 02/01/1975

ELIET EUROPE NV  
Diesveldstraat 2  
BE - 8553 Otegem Belgium  
Ph. +32 56 77 70 88 - Fax +32 56 77 52 13  
info@eliet.eu - www.eliet.eu



## 15. Appendices

---

### 15.1 Hazard analysis:

---

Below you will find a list of dangers and risks that are linked to transporting or using the snow blower. Take note of these dangers and avoid these risks by following the instructions contained in this manual. Be aware that it is not just the user who runs a risk but also third parties can be exposed to these risks. Make sure that bystanders are always kept at a safe distance.

- Injuries to arms and hands placing them into the machine when it's working.
- Injuries to arms and hands placing them underneath the machine.
- Injuries caused by chippings flying out from the discharge opening when the machine is in operation.
- Strangulation or constriction by loose clothing getting caught in moving parts.
- Jamming/pinching of the shielding panels swinging shut.
- Accidental head-bumping when carrying out maintenance on shielding panels when hinged open.
- Burns following contact with a hot engine or hot exhaust.
- Fire hazard caused by faulty engine cleaning.
- Fire hazard due to spilling petrol.
- Fire hazard due to batterie blockage.
- Intoxication by inhaling exhaust gases.
- Jamming or constriction of limbs becoming entangled in the belt drive or chain drive due to missing safety guards.
- Back problems caused by lifting the machine in an irresponsible way.
- Injury due to a fall while driving on a soil that cannot support the weight of the machine.
- Injuries caused by the machine tipping due to unsafe transport.
- Sprain caused by jumping off the machine on a sudden change in drive direction.

...

This is not a comprehensive list and is provided for information purposes only to safeguard the safety of the user.

## 15.2 Meter display and functions

---

### METER DISPLAY AND FUNCTIONS

Digital Display: Total Usage (hours) or Engine Speed (RPMs)

Clock: Meter is in Usage mode displaying total hours

RPM: Meter is in Tachometer mode displaying RPMs

Oil Can: Change/Check engine oil

Wrench: General maintenance (see Owner's Manual)

Filter: Change/Service air, oil, or pre-cleaner filters

Arrows: Label indicates which filter(s) need(s) servicing

### METER INSTALLATION

1. Clip on the black plastic sensor over any convenient spark plug wire. Make sure the sensor is completely seated down on the spark plug wire so there is no air gap.
2. Attach the ground wire ring terminal to any convenient bare metal surface on the engine or frame. Typically an existing engine fastener can be used.
3. Route the sensor lead wire and mount the meter. CAUTION: Keep meter and wire away from EXTREMELY HOT engine surfaces or possible interference. Extra lead wire can be coiled-up out of the way. See separate instructions for mounting meters with double-sided tape.
4. Attach the sensor tamper-proof lock.

**NOTE:** These installation steps may have already been performed by your original equipment manufacturer.

### METER OPERATION

- All meter functions are controlled by pressing the Mode Button which is located on the lower face of the meter.
- Pressing the Mode Button at any time switches back and forth between Usage mode and Tachometer mode. Some meters are configured to stay in a single mode and do not switch.
- Pressing and holding the Mode Button for four (4) seconds clears flashing Maintenance Alert Icons.

### USAGE METER MODE

- The meter automatically senses whenever the engine is running and keeps track of the actual total accumulated hours of operation. The clock icon flashes at one second intervals to indicate the meter is counting in Usage Mode.
- Total time is displayed in hours and tenths of an hour. Every six (6) minutes the smaller tenths digit increments.
- Total engine usage always accumulates regardless whether the meter is in Tachometer Mode or Maintenance Alert Icons are flashing.
- After 9999.9 hours the meter restarts back at 0.0 hours.

### **TACHOMETER METER MODE**

- Current engine speed is displayed in revolutions per minute (RPM) in increments of 20 RPM. The RPM icon stays on to indicate the meter is in Tachometer Mode.
- RPMs up to 9999 are displayed on the four large digits. If RPMs exceed 10000 the smaller far right hand digit is also used.
- Meters automatically switch from Tachometer Mode to Usage Mode when the engine is stopped and RPMs drop to zero.

### **MAINTENANCE ALERT ICONS**

- The meter is programmed based on the recommended maintenance schedule of your engine and implement manufacturers. Check your Owner's Manual(s) for additional detailed maintenance information. A table is provided on the next page to record your maintenance events.
- Maintenance Alert Icons flash when servicing is due, regardless of the mode the meter is in, Usage or Tachometer. After maintenance is completed, reset the flashing icons by PRESSING and HOLDING the Mode Button until the icon clears (takes approximately four (4) seconds).
- **FIRST ALERT:** Servicing your new engine after the initial break-in is crucial. When a new engine has been broken-in ALL ICONS FLASH on the meter. Perform the maintenance specified in your Owner's Manual.
- The Oil Can Icon indicates servicing is required on the crank case oil. The Wrench Icon indicates general maintenance is required as prescribed in the Owner's Manual.
- The Filter Icon is used in conjunction with arrows pointing to "AIR", "OIL", and/or "PRE" printed on the meter label to indicate servicing is required on the air filter, oil filter or air pre-cleaner. The arrows may point to other engine or implement maintenance events printed on the label.
- Following the manufacturer's recommended maintenance schedule extends the performance, longevity and environmental compliance of the engine.

## 15.4 Warranty

---

Dear Customer,

We thank you for purchasing an ELIET product. Congratulations on your choice of this machine which is sure to meet your expectations and needs over the coming years. At ELIET, we are committed to guaranteeing the correct functioning of our products. That's why you can rely on ELIET's 2-year warranty after purchase.

### **What is warranty ?**

ELIET's product design and manufacture procedures are subject to strict quality guidelines. These are aimed at guaranteeing a long service life and permanent safety. To ensure this, ELIET will repair any hidden faults or abnormalities free of charge throughout the break-in period (the warranty period), provided the prescribed procedure is followed.

### **Warranty conditions**

ELIET's warranty obligation for new machines is governed by the following conditions:

#### **I. Warranty period**

The warranty period shall start on the date when the Eliet dealer delivers the machine to the customer (maximum 1 week after the machine was delivered to the dealer) and shall expire:

- after two years in domestic use
  - after twelve months or 100 running hours for rental use
  - after twelve months or 100 running hours in semi-professional or in professional use
- Customers who wish to benefit from this warranty, must register their purchase by returning the filled in registration form to Eliet Europe. From September 2008, they must register their purchase online at [www.eliet.eu](http://www.eliet.eu)

#### **II. What's excluded from this warranty ?**

- Wear items are not covered by the warranty conditions: (e.g. blades, bearings, belts, chains, gearwheels, tyres, bulbs, fuses, etc).
- If failures are found to be caused by improper use, neglect or consequential damages by an external source (fall, chippings, foreign objects, accident).
- When the failure is found to be caused by failure to maintain the machine in accordance with the prescribed periodic maintenance.
- If a defect develops after service completed by anyone other than an authorized ELIET dealer or after using not genuine ELIET service parts.
- If the defect is a result of the unauthorised modification of the machine's original design.
- If the failure occurs when the machine is used in a way other than as recommended by the instructions specified in the manual.
- If the prescribed warranty procedure has not been adhered to or when the warranty period has

expired.

- For problems with the engine, contact a factory authorized service station of the engine make.

### **III. Procedure**

- **Step 1:** The enclosed registration cards should be completely filled out at the moment of purchase. The first form should be returned to ELIET within one month. The customer shall retain all other copies and the purchase invoice until the warranty expires. The customer shall register the purchase at **www.elieta.eu** (active from September 2008).
- **Step 2:** In the event of a defect becoming apparent, the customer shall have this verified by his/her authorized ELIET dealer. If the dealer feels that there is a factory defect, this dealer may invoke the warranty, under the terms specified.
- **Step 3:** Every warranty claim shall be accompanied by a fully completed official application form. Dealers can request these forms from ELIET or the ELIET import agent.
- **Step 4:** The dealer orders the parts needed to perform the repairs. The dealer then faxes the order form together with the completed warranty form and a copy of the registration card.
- **Step 5:** The warranty form should be stapled to the purchase invoice and sent to ELIET or the ELIET import agent.
- **Step 6:** ELIET shall send the ordered parts to the dealer under normal delivery and payment conditions
- **Step 7:** ELIET Technical Service Department shall examine the faulty component before accepting or rejecting any warranty claim. ELIET shall retain the right to decide whether the customer has complied with the conditions governing the validity of this one-year or two-year warranty. Faulty components shall become the property of ELIET.
- **Step 8:** If a warranty claim is found to be valid, ELIET shall credit the warranty parts. Labour costs of repair shall never be refunded.

### **IV. In case of damage caused by transport**

- Goods are supplied ex-works. The transport risks shall be borne by the customer. Therefore, Eliet stresses the importance of examining the goods at the time of delivery.
- Any damage should be stated on the delivery form before it is signed. Have the driver add a signature alongside this statement on your copy.
- In the absence of this written, signed statement on the delivery form the transport insurance will not accept any liability.
- Damages may be claimed from the hauler using a copy of the delivery form and a covering letter stating your complaint.
- The machine should be kept in its original condition until the hauler's insurer has examined it.

**REGISTRATIONCARD****ELIET CUSTOMER SERVICE**

To be able to claim the full rights to which you are entitled, it is important to register within a month after the date of purchase. Therefore fill out this registration form and return the first registration card to the ELIET Customer Service. Your purchase should be registered on the ELIET website: [www.eliel.be](http://www.eliel.be)

**REGISTRATIEKAART****ELIET KLANTDIENST**

Om als klant, aanspraak te kunnen maken op waarborg dient men zich binnen de maand na aankoop bij ELIET te registreren. Hierop vult u onderstaand document volledig in en stuurt het eerste deel van deze registratiekaart naar de ELIET klantendienst terug. Registreer uw aankoop op de ELIET website: [www.eliel.be](http://www.eliel.be)

**CARTE****SERVICE**

Pour profiter de tous les avantages auxquels vous êtes éligible, il est important de vous inscrire dans le mois suivant l'achat. Complétez donc soigneusement et renvoyez cette première partie de la carte au Service Clientèle ELIET. Enregistrez votre achat sur le site Internet ELIET: [www.eliel.be](http://www.eliel.be)

**ELIET**
 Registration card  
 Registratiekaart  
 Carte d'enregistrement  
 Registrationskarte

 ELIET Customer Service  
 Zwavelstraat 136  
 B-8003 Odegem  
 Belgium

 Please return the first registration card to the ELIET Customer Service. Register on the ELIET website: [www.eliel.be](http://www.eliel.be)
**Customer Identity / Klantgegevens / Données du Client / Kundendaten**

Name / Naam / Nom / Name		First Name / Voornaam / Prénom / Vorname	
Street / Straat / Rue / Strasse		Nr / Nr / N° / Nr	Box / Bus / Boîte / App.
City code / Postnr / Code Postal / Postleitzahl		City / Plaats / Ville / Stadt	
Country / Land / Pays / Land		Country / Land / Pays / Land	
Telephone / Telefoon / Téléphone / Telefon-Nr.		Fax / Fax / Télécopieur / Fax	
E-mail			

**Machine Identity / Machinegegevens / Données de machine / Daten Maschine**

Model / Model / Modèle / Model		Year of manufacture / Bouwjaar / L'année de construction / Baujahr	
Article Code / Artikel code / Code d'article / Artikel-Nr.		Serialnumber / Seriennummer / Numéro de série / Serien-Nr	
Date / Datum / Date / Datum			
Signature Handtekening Signature Unterschrift		Stamp of dealer Stempel van handelaar Cachet de revendeur Stempel Fachhändler	

I declare that all information that was filled in is correct and truthful. I also declare to have read and understood the operating manual and the warranty conditions. Je déclare que toutes les données complétées sont correctes et véridiques. Je déclare également d'avoir lu et compris les notices du mode d'emploi et les conditions de garantie.

Put a crossmark to which application this machine was used. Zet een kruis bij de toepassing waarbij deze machine wordt ingezet. Indiquez avec une croix l'emploi dans lequel la machine a été utilisée. Kreuzen Sie an, für welche Art von Gebrauch die Maschine bestimmt ist.

- Home use / Particulier gebruik / Usage particulier / Private Nutzung
- Professional Landscaping / Hoveniersbedrijf / Usage Professionnel / Gewerbliche Nutzung
- Forestry / Bosbouw / Forêt / Forstbetrieb
- Public Groundscare / Openbare groenvoorziening / Espaces Verts Public / Öffentliche Grünflächenversorgung
- Rental / Verhuur / Location / Vermietung

**Dit document dient binnen de maand na aankoop teruggestuurd te worden naar de ELIET Klantendienst.**  
**This document has to be returned to ELIET Customer Service within a month after purchase.**  
**Remettez ce document au Service après-vente ELIET dans le mois suivant à la date d'achat.**  
**Dieses Dokument muss innerhalb eines Monats nach Kaufdatum an den ELIET Kundendienst zurückgeschickt werden.**

